

BATELCO JOINT WORKING MANUAL

1. INTRODUCTION

1.1 Framework and Function

This Joint Working Manual is part of the Supply Terms.

The primary function of the Joint Working Manual is to specify the procedures to be established by parties and the other activities to be undertaken by parties to plan, implement, manage and change intercarrier arrangements between their Networks, including to forecast traffic loadings, for one party to order Capacity from the other and for joint testing before such Capacity is brought into service.

A secondary function of the Joint Working Manual is to record from time to time technical and operation information which if it is included in the Supply Terms, may render those terms unmanageable.

2. PLANNING

2.1 Introduction

This Paragraph 2 describes the joint approach to the planning of interconnection between their Networks and the provision of Services by one party to the other party.

2.2 Technical review meetings

The principal forum for the initial and ongoing technical and planning discussions between the parties will be the technical review meeting.

The items to be covered by the meeting are:

- routing plans
- capacity profiles, traffic forecasts and records
- interconnect planning
- technical support for the provision of interconnect capacity

2.3 Planning the Initial Interconnect

Interconnection between the Licensed Operator and Batelco requires detailed planning to ensure that the two Networks interwork correctly and that neither Network causes service problems for the other. A listing of the activities involved in delivering Interconnection is shown in Annex 2 to this Paragraph 2 (**End to End Interconnect Activity Listing**).

2.3.1 Initial Statement of Requirements

Batelco will work with the Licensed Operator to prepare a statement of requirements for the Interconnection. Discussions will be held between the Licensed Operator and Batelco to establish the proposed nature of the Interconnection, the services and facilities that are required to interwork between the two Networks, the physical locations of the Points of Inteconnection, the physical realisation of the transmission links and the type and Build Level of the switch(es) to be connected to the Batelco Network.

The Licensed Operator shall provide the required information using the forms contained in the Appendices to this Joint Working Manual. Explanatory notes to assist with the completion of forms are provided where necessary.

The parties will exchange details of their Networks to enable planning of the initial Interconnection. The contact details for the exchange of this information will be provided by each party using the contact register set out in Appendix 31 of this Joint Working Manual (Contact Register).

2.3.2 Initial Technical Planning

The technical review meeting will co-ordinate the initial technical and planning arrangements that culminate in interconnecting the Licensed Operator Network with the Batelco Network using In-Span Interconnect.

The initial technical review meetings will address the following details:

- transmission plan (including principles for tributary allocation)
- traffic routing plans
- switch connections
- numbering information
- switch details
- switch testing
- network performance
- resilience, diversity and security
- call handling sequences
- traffic forecasting
- capacity profiles- power requirements
- Operations and Maintenance principles

- circuit usage and release programs
- emergency calls
- data management amendments
- Interconnection services required
- transmission time

All the above details will be documented in the Technical Master Plan.

The Technical Master Plan will be used by the Batelco CSD to validate orders received from the Licensed Operator. Orders which do not comply with the Technical Master Plan may be rejected with a statement setting out reasons for non-compliance by reference to the relevant part of the Technical Master Plan.

Forecasts, Capacity Profiles and Advance Capacity Orders will be required to be provided by each party. The format of this information and how it should be provided is detailed in Paragraph 4 of this Joint Working Manual (Forecasts and Capacity Profiles).

Each party will produce and provide routing plans (ingress and egress) for its Network. Examples of routing plans can be found in Appendix 28 (Routing Plans). Each party will present its routing plan for discussion at the technical review meeting and will give reasonable consideration to other party's comments about changes which will make Interconnection and supply of access services more efficient or improve end to end service quality across the interconnected Networks.

The technical standards for the specification of electrical and physical interfaces, signalling and transmission are contained in Appendix 1 (Technical Specifications).

2.3.3 Provision of Capacity

Once the Licensed Operator and Batelco have signed the Supply Terms, and the Licensed Operator has provided Batelco with the information pursuant to the Supply Terms, the Licensed Operator may provide a formal order to Batelco for the provision of Capacity.

The provisioning activities and other procedures required to fulfil orders for new In-Span Interconnect or CSI and for orders and changes to the Interconnection between the Licensed Operator and Batelco are described in Paragraphs 5 and 6 (Interconnect Link and Cessation of Capacity).

Annex 2 - End to End Interconnect Activity List

Start Planning	Interface Specification Conformance
Confirm Switch Choice	Confirm Transmission Equipment
Network Information	Confirm Switch Connection Proposals
Pre-requisites Agreed	Agree Interconnect Traffic Routing
Supply Forecast	
Supply Capacity Profile	Start O and M Discussions
Start Implementation	Build duct and Footway Box
Connect duct to Footway Box	Cable handover
Test fibre	Transmission End to End Commissioning
Transmission Operational Process Testing	Transmission Stability Testing
Install New Traffic Routes	Agree First Live Traffic Testing
RFT Declared	First Live Traffic Testing
Check Test Results	Operational Field Trial
Bring Into Service	Activate Ingress/Egress Routing

3. TECHNICAL SPECIFICATION

3.1 Introduction

This Paragraph 3 describes the technical specifications applicable to the Services. The specifications in this paragraph are applicable to each party as Access Seeker and as Access Provider in respect of each relevant Service.

3.2 Core Technical Characteristics

The core technical characteristics of interconnection and the responsibilities of each party are set out in Appendix 1 (Technical Specifications).

3.3 Technical characteristics for the Interconnect Service

3.3.1 Principles

The Interconnection Link is a service which links a Licensed Operator Switch Connection to the Batelco Gateway Switch using a Carrier System which is the end to end physical and logical connection between the two.

The Interconnect Link may be established by either (at the Licensing Operator's election):

- (a) an In-Span Interconnect Service; or
- (b) a CSI Link Service.

Carrier Systems based on Synchronous Digital Hierarchy (SDH) 155.52 Mbit/s (STM-1) only will be used. The basic sub-rate of all Carrier Systems is 2.048 Mbit/s.

A 155 Mbit/s Carrier System is capable of supporting sixty-three 2.048 Mbit/s Interconnect Links. Figure 1 represents a functional overview of the service.

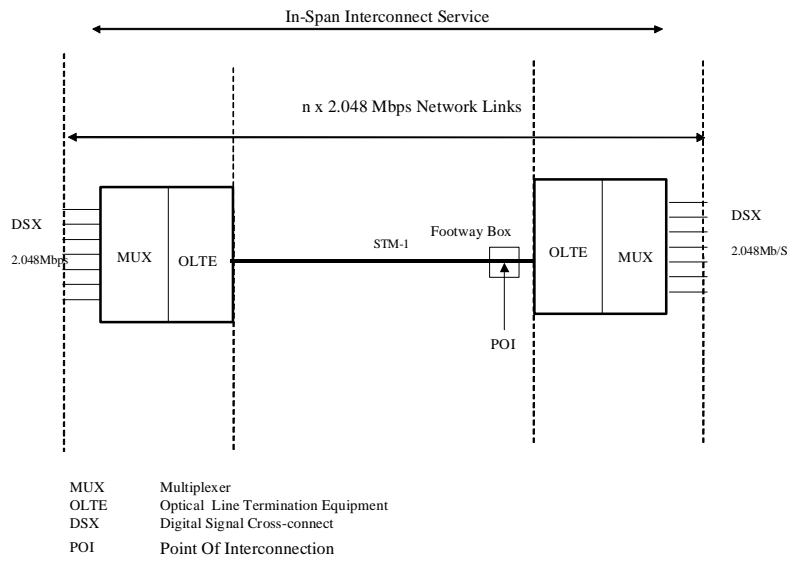

Figure 1a The Carrier System, ISI

Customer Sited Interconnect

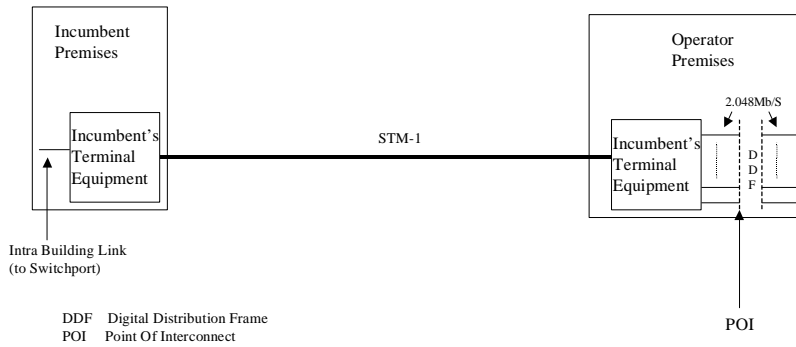

Figure 1b The Carrier System, CSI

Single mode optical fibre cable specifications are set out in Appendix 10 (Optical Fibre Cable Performance Specification) and Appendix 11 (Optical Fibre Cable Specification).

The physical interface between the Licensed Operator Network and the Batelco Network will be the STM-1 fibre interface.

3.3.2 Process for accreditation of circuit terminating units

All circuit terminating unit equipment must conform to SDH standards and any additional standards specified in the Joint Working Manual.

3.3.3 Footway Box engineering drawing

If the Interconnect Link is established by a CSI Link Service, the specification of the Footway Box will be provided in the form of an engineering drawing, a copy of which is set out in Appendix 6 (Footway Box Engineering Drawing).

3.4 2.048 Mbit/s sub-rate characteristics

The electrical, functional and synchronism characteristics of the 2.048 Mbit/s sub-rate streams are set out in Appendix 2 (Specification of the Generic Electrical and Physical Interface).

3.5 Transmission Interface

The transmission characteristics (such as loudness and echo) are set out in Appendix 3 (Specification of the Generic Transmission Interface).

3.6 Signalling

Signalling applied shall be Signalling System No. 7 which conforms to ITU-T standards (White Book). Operator dependent implementations of the signalling protocol at the network interconnection interface will not be supported.

The specification of the signalling system is set out in Appendix 4 (Specification of the Generic Signalling System for Interconnection).

3.7 Short Message Service

Where the Service Description includes provision for the delivery or reception of GSM Short Message Service (**SMS**) messages, then the specifications and procedures set out in Appendix 5 (GSM Short Message Service) shall apply.

4. FORECASTS AND CAPACITY PROFILES

4.1 Responsibilities

There are four service types associated with interconnection:

Traffic flow	Egress from or ingress to	Responsibility (as Access Seeker)	Example
Licensed Operator to Batelco	Egress from Licensed Operator Network, termination on Batelco Network	Licensed Operator	Batelco provided PSTN Terminating Access Service
Licensed Operator to Batelco	Ingress to Batelco Network, termination on Batelco Network	Batelco	Licensed Operator provided Premium Rate Originating Access Service
Batelco to Licensed Operator	Ingress to Licensed Operator Network, termination on Licensed Operator Network	Licensed Operator	Batelco provided Freephone Originating Access Service
Batelco to Licensed Operator	Egress from Batelco Network, termination on Licensed Operator Network	Batelco	Licensed Operator provided GSM Terminating Access Service

For the purposes of paragraphs 4, 5 and 6, a party (the first party) shall provide the other party with a Forecast, Capacity Profile and Advanced Capacity Order which aggregates the egress traffic from the first party's Network and to the other party's Network and the ingress traffic to the first party's Network from the other Party's Network for which the first party as the Access Seeker.

4.2 General

This Paragraph 4 describes the procedures to be used by the Access Seeker to provide Forecast and Capacity Profile information and gives guidance on how the information should be presented. The requirements for Forecasts are set out in clause 15 of the Supply Terms (Forecasting) and in this Joint Working Manual.

4.3 Forecasts

Forecasts for each switch connection shall be supplied by each party as Access Seeker to the other party as Access Provider quarterly, in accordance with this Joint Working Manual.

The Forecasts should be compiled using the forms with explanatory notes contained in Appendix 19 (Interconnect Traffic Requirements: Summary).

The activities in the Forecast procedure to be followed by the Licensed Operator and Batelco for the handover of the Forecast, analysis of the Forecast and response to the Forecast is shown in Annex 4A to this Paragraph 4 (Forecast Procedure).

4.4 Capacity Profile and Advance Capacity Orders

Capacity Profiles for all existing and proposed switch connections shall be supplied quarterly by each party as Access Seeker to the other party as Access provider.

The first 4 months of each Capacity Profile shall form an Advance Capacity Order. The failure by the Access Seeker to subsequently order at least this amount of Capacity by way of a Capacity Order may lead to charges in accordance with the Supply Terms.

The Capacity Profile for capacity provision and Capacity Re-arrangement should be compiled separately using the form with explanatory notes contained in Appendix 20 (12 Month 2 Mbit/s Switch Port Capacity - Ordering Profile).

The activities to be followed by the parties in the Capacity Profile procedure are shown in Annex 4B to this Paragraph 4 (Capacity Profile Procedure).

Annex 4A - Forecast Procedure

Activity Name	Activity Descriptions	Owner
Access Seeker provides Forecast to Access Provider	The Access Seeker sends Forecast to the Access Provider.	Access Seeker
Access Provider analysis of Forecast	The Access Provider assesses the capability of its network to meet the Forecast supplied by the Access Seeker. The Access Provider will seek clarification from the Access Seeker of any queries that arise from the assessment.	Access Provider
Access Seeker response to Access Provider queries	The Access Seeker responds to queries on the Forecast raised by the Access Provider.	Access Provider
Access Provider signs and returns copy of Access Seeker Forecast	When any queries have been satisfactorily resolved the Access Provider will write to the Access Seeker to advise that the Forecast is agreed and return a signed copy of the document.	Access Provider

Annex 4B – Capacity Profile Procedure

Activity Name	Activity Descriptions	Owner
Access Seeker provides Capacity Profile to Access Provider	The Access Seeker sends Capacity Profile to the Access Provider.	Access Seeker
Access Provider analysis of Capacity Profile	The Access Provider assesses the capability of its network to meet the Capacity Profile supplied by the Access Seeker. The Access Provider will seek clarification from the Access Seeker of any queries that arise from the assessment.	Access Provider
Access Seeker response to the Access Provider	The Access Seeker responds to queries on the Capacity Profile raised by the Access Provider.	Access Seeker
Parties agree the Capacity Profile	The Batelco and Licensed Operator review each Capacity Profile supplied by the Access Seeker at the relevant technical review meeting. If it is agreed, the Capacity Profile will be signed off by the authorised representatives of each party.	Batelco and Licensed Operator
First 4 months of Capacity Profile forms an Advance Capacity Order	The first 4 months of each Capacity Profile, which has been signed off by both parties forms an Advance Capacity Order.	Access Seeker

5. INTERCONNECTION

5.1 Introduction

This paragraph describes the provisioning activities required for the Interconnection of a new Licensed Operator switch with Batelco switches via a Customer Sited Interconnect (CSI), the provision of new a Interconnection Link via an In-Span Interconnect (ISI) between existing switches, new Interconnection traffic routes and the rearrangement of Capacity on an existing route.

5.2 Procedures And Task Overview

5.2.1 Preliminary Planning

Technical issues (for example, routing requirements for new switches or routes) must be discussed at the technical review meeting forum prior to a Capacity Order being placed. These are described in Paragraph 2 (Interconnect Planning).

5.2.2 Capacity Profile and Advance Capacity Order

Before placing Capacity Orders (other than Advance Capacity Orders), the Access Seeker shall supply Access Provider with a Capacity Profile in relation to Capacity provision and Capacity Rearrangement.

The first 4 months of each Capacity Profile agreed by Access Provider shall form an Advance Capacity Order. Further information concerning Capacity Profiles and Advance Capacity Orders can be found in Paragraph 4 (Forecasts and Capacity Profiles).

5.2.3 Capacity Orders

Capacity Orders will be provided by the Access Seeker to Access Provider. An example of an order form and explanatory notes are contained in Appendix 26 (Capacity Order Form).

Capacity rearrangements are restricted to moves and changes within a particular building. A change which necessitates a connection being moved from one building to another shall be regarded as the termination of one link and the provision of another.

5.2.4 Provision of Interconnection

The key activities for the provision of new capacity by In Span Interconnection are shown in Annex 5A.

The key activities for the provision of new capacity by Customer Sited Interconnect are shown in Annex 5B.

5.3 Testing Requirements

5.3.1 Process

The testing procedures required under this Joint Working Manual are set out in Appendix 30 (Testing Procedures).

The parties shall jointly agree test plans in accordance with Appendix 30 (Testing Procedures). Each test plan shall include all required tests to be performed at specified intervals throughout the implementation of the relevant Interconnection or Capacity Order and the contact names and telephone numbers of the representatives of the respective parties.

Both parties shall sign the relevant test plan in advance of the commencement of testing. Any delay in signing the test plan may result in consequential delay of all previously scheduled implementation dates.

If either party cannot proceed with the tests as scheduled, a new date mutually convenient to both parties will be agreed between the nominated operational people in both parties and advised to the Batelco CSD. In the event of testing difficulties which cannot be resolved quickly by the people carrying out the tests, a defined escalation procedure will be followed. This is shown in Appendix 27 (Testing Escalation Process).

5.3.2 Testing approach

Testing is performed to ensure that connection of capacity to the Access Provider network will not have adverse effects on the network and customers of either company.

Testing requirements for the first route between the Licensed Operator switch and the Batelco network will consist of a combination of three activities, namely Interface Validation Testing (IVT), Network Interworking Tests (NIT) and Operational Testing. The combination will depend on whether the proposed Switch Type / Build combination and Facilities to be used have been connected to the Batelco network previously.

Testing of subsequent routes and additional capacity on existing routes will require operational testing only, provided that the build, facilities and service types have not changed since the previous capacity provision.

5.3.3 New Switches

New Licensed Operator Switch Connection will be identified by the Licensed Operator at the technical review meetings and switch information, including an SS7 specification conformance statement will be provided by the Licensed Operator to identify the switch type, build and the services and facilities to be carried. The relevant form for the switch information together with explanatory notes are contained in Appendix 16 (Switch Information). The choice of switch and build for Licensed Operator Switch Connections will affect the level of testing required to ensure that its connection to the Batelco Network will not have adverse effects on the Network of either party.

The implications of the chosen switch and Build Level may be the subject of a technical meeting between the parties called by either party. Batelco will compare the information supplied by the Licensed Operator to the known build of switches connected to the Batelco Network and if differences are identified may ask the Licensed Operator to complete an interconnect change advice form. A copy of the form with explanatory notes is contained in Appendix 17 (Interconnect Change Advice Forms). Batelco will provide an initial assessment of the level of testing required on the basis of the information supplied.

5.3.4 New Switch Testing Requirements

Switches and builds for Licensed Operator Switch Connections, which are known to Batelco in the application proposed, will require a minimum amount of testing. Switches which have been tested but for different applications or at different builds may require an intermediate level of testing. A switch that is substantially different in build or implementation will need a Network Interworking Test (NIT) with a Batelco captive model. A new switch system or major build change will need an Individual Location Test (ILT) using a protocol simulator in addition to the NIT. A list of known switches and builds is contained in Appendix 7 (List of Switch Builds and Platforms).

5.4 Testing

5.4.1 In-Span Interconnection specific testing

The manufacturer and type of equipment, which Batelco shall use to transmit In-Span Interconnect, are listed in Appendix 8 (Transmission Systems for In-Span Interconnect).

Every order placed by a Access Seeker for In-Span Interconnect shall be accompanied by a tributary assignment form. An example of this form is contained in Appendix 9 (Tributary Assignment/Allocation Forms).

Tributaries shall be assigned in accordance with the agreed transmission plan contained in the Technical Master Plan.

The joint procedures for testing STM 1 SDH optical line systems are outlined in Appendix 13 (Testing of Optical Line Systems for In-Span Interconnect). Once the line systems have been tested each party will offer the results to the other to demonstrate acceptable performance.

The joint procedures for end to end multiplex tributary testing are outlined in Appendix 14 (Joint Procedures for End to End Multiplex Tributary Testing).

5.4.2 General requirements

The single mode optical fibre cable performance specification is contained in Appendix 10 (Optical Fibre Cable Performance Specification).

The optical fibre cable specification is contained in Appendix 11 (Optical Fibre Cable Specification).

The optical fibre provided will be jointly tested and the results recorded. The optical fibre acceptance procedure is outlined in Appendix 12 (Optical Fibre Acceptance Procedures).

Before working on optical fibres it is essential that appropriate safety measures are taken. These are described in Appendix 15 (Safe Working Procedures for Optical Fibre Cables).

5.4.3 First Live Traffic Testing

Any new switch validation process will need to have been completed before a new Licensed Operator switch can be connected to the Batelco Network for First Live Traffic Testing.

The First Live Traffic Testing phase is used to check that the switch data and network equipment is suitable for connection to the Batelco Network. The level of First Live Traffic Testing required is based on the fact that the switch build has already undergone a validation exercise. Different test scenarios will be required depending on what is being tested. The testing scenarios are set out in Appendix 30 (Testing Procedures).

As part of the Batelco order handling process the Batelco CSD will collate the dates for completion of the project and will confirm the required Ready for Test (RFT) date to the Licensed Operator. The RFT date will be offered to the Licensed Operator by the Batelco CSD and the parties will jointly agree the start date for First Live Traffic Testing. If the parties fail to agree on an acceptable date for the testing they should follow the disputes procedure referred to in Annexure 6 to the Supply Terms (Dispute Resolution Procedures).

Prior to the scheduled RFT date (or other agreed date), all Carrier Systems, 2.048 Mbit/s Interconnection Links and signalling links to be used during acceptance testing must be in place and, where relevant, NIT and ILT must have been successfully completed.

At least five (5) Working Days before the scheduled RFT date (or other agreed date), Batelco shall advise the Licensed Operator whether all necessary provisioning has been completed and acceptance testing can commence.

A RFT certificate will be sent by Batelco to the Licensed Operator to certify that the capacity is RFT. An example is contained in Appendix 24 (RFT Certificate).

All acceptance test results will be recorded in a test report in accordance with Appendix 30 (Testing Procedures) and both parties will retain copies for future reference.

If the acceptance testing is successful, each party will sign the acceptance test reports within five (5) Working Days of completion.

On the Ready for Service (RFS) date, subject to satisfactory First Live Traffic Testing and Operational Field Trial, both parties shall certify that the capacity has been satisfactorily tested by signing the switch to switch interconnection authorisation certificate for in service use set out in Appendix 25 (Switch to Switch Interconnection Authorisation Certificate).

If acceptance testing is unsuccessful within the initially agreed time frame, the parties may agree on a partial acceptance testing, with the understanding that full compliance will be met by an agreed date.

If either party cannot accept the Interconnection or Capacity with partially successful acceptance testing, then the reasons for non-acceptance should be documented and the report signed indicating non-acceptance. The parties will agree what action should be taken, including any timeframe for remedial work and re-testing. Any disputes will be resolved in accordance with the dispute resolution procedure set out in Annexure 6 to the Supply Terms (Dispute Resolution Procedures).

5.5 Bringing Into Service

Once the Interconnection has been successfully tested the Capacity will be available for use by the Licensed Operator. Unless the Licensed Operator requests otherwise the testing data will be removed and in service routing data will be provided.

Batelco will check that all relevant technical and commercial issues are in order and will advise the Licensed Operator that the route is open for customer service. An example of the form to be used by Batelco is set out in Appendix 22 (Interconnect Order Completion).

5.6 Changes To Switch System Builds

5.6.1 Change notification

Proposed changes to switch system builds relating to specifications for SS7 ISUP interconnection must be notified by the party proposing the change, with details of the proposed change using the form contained in Appendix 17 (Interconnect Change Advice Forms). The parties will jointly assess the implications of the proposed change and agree on the level of testing.

When a “new build” has been tested satisfactorily it will be registered as a known build for connection to the Batelco Network for First Live Traffic Testing. Batelco will issue a First Live Traffic Testing certificate, which authorises the connection of the Batelco Switch and Licensed Operator Switch for testing purposes. A copy of the form is contained in Appendix 18 (Authorisation Certificate for First Live Traffic Testing). Batelco and the Licensed Operator will then be in a position to progress the arrangements for First Live Traffic Testing.

5.6.2 Switch Hot Changeover

- Batelco will accept the ‘Hot Changeover’ (i.e. the in-service change of one switch type for another) of switches by Licensed Operator subject to the conditions below:
- The new switch replaces an existing in-service switch.
- The new and old switch will use the same Point Code unless otherwise agreed.
- Services and applications that the Licensed Operator new switch is using have previously been tested.
- No additional functionality is added to the switch as a result of the changeover (if additional functionality is provided it must be turned off until suitable assessment is made).
- Both Batelco and the Licensed Operator have the right to monitor the routes after changeover and request Operational Testing to take place should calls fail or other anomalies occur.

- The new switch has undergone operational testing by the Licensed Operator after commissioning by the manufacturer, and the results made available to the Batelco CSD in advance of the changeover.
- The Licensed Operator must retain the option to revert the route(s) to the previous switch should serious network management conditions occur (in either network) as a result of the changeover.
- The Licensed Operator must accept that any faults that occur during or immediately following such changeovers are on their network, as the routes have been previously tested, and progress resolution of such faults accordingly.
- The Licensed Operator agrees that only one new switch is changed over at a time, i.e. further switches must wait until an agreed (with the Batelco CSD) assessment period has passed.

Annex 5A - Key Activities – InSpan Link Service

Activity Name	Activity Descriptions	Owner
Capacity Order and Tributary Allocation to Access Provider	The Access Seeker sends Capacity Order and, where relevant, details of the tributary allocation proposed by the Access Seeker using the tributary assignment form to Access Provider.	Access Seeker
Order validation by Access Provider	Access Provider will validate the Capacity Order against the agreed arrangements for the Interconnection contained in the Technical Master Plan. An invalid order will be rejected and the Access Provider will provide an explanation of the non-compliance. Order Validation will be by way of the form in Appendix 21.	Access Provider
Network Capacity Assigned	Batelco assigns line terminating equipment and intra building links for the 2 Mbit/s sub-rate streams.	Batelco
InSpan Planning Meeting	In-Span Interconnect planning meeting between representatives of the Licensed Operator and Batelco to discuss and agree issues relating to the order for In-Span Interconnect. The issues will, where relevant, include: the location of the Footway Box, the type of Add Drop Multiplexer to be used, the cable specification and laser safety.	Meeting arranged by Batelco.
Street Works Application*	If street works are required to allow either party to lay new duct or to build a Footway Box then application(s) will need to be made to the relevant authority for permission to carry out this work.	Application is submitted by Batelco and/or the Licensed Operator.
Street Works Clearance satisfactory?*	The response to the application(s) for permission to carry out street works is received and if permission(s) is granted civil engineering may commence. If permission is refused or if the result is to delay the work then this information is given to the other party and a further In-Span Interconnect planning meeting held to discuss the implications. The outcome may be to accept the delay or agree an alternative route for which a new street works application will be made.	The party making the application will advise the other party of the result of the application and arrange a further meeting if necessary.
Civil Engineering Complete*	Batelco and/or the Licensed Operator has completed the civil engineering work required to build the Footway Box.	Batelco / Licensed Operator
Hand Over Connecting Cable*	The In-Span Interconnect is established by either Batelco or the Licensed Operator bringing the cable to the Footway Box. Where, it is either joined to the other party's cable or, if agreed and the cable meets the required standards, then a suitable length can be handed over to the other party to be drawn into the other party's building. There should be a planned and coordinated hand-over of the cable from one Licensed Operator to the other.	Batelco / Licensed Operator
Handshake Fibres	Batelco and the Licensed Operator agree that	Batelco and

Activity Name	Activity Descriptions	Owner
Safe*	appropriate safety measures are in place prior to working on the optical fibres. See Appendix 15 (Safe Working on Optical Fibre Cables)	Licensed Operator
Fibres Tested*	The method of acceptance testing the fibre optic cable is detailed in Appendix 12 (Optical Fibre Acceptance Procedures). The responsibility for carrying out the acceptance tests lies with Batelco. The test results shall be copied to the Licensed Operator.	Batelco
Results satisfactory?*	Analysis of the results of the acceptance tests on the fibre optic cable should be agreed by both parties. If the results are unsatisfactory, remedial action should be taken and the fibre optic cable re-tested.	Batelco and Licensed Operator
In House Install and Test Add Drop Multiplexer*	Each party shall arrange the installation and testing of their own Add Drop Multiplexer	Batelco and Licensed Operator
SDH System Complete*	The fibre optic cable and Add Drop Multiplexer are installed and the test results are satisfactory. A date is arranged for the joint SDH testing.	Batelco and Licensed Operator
SDH System Tested*	The procedure for the joint (Batelco/Licensed Operator) testing of the SDH system is in Appendix 13 (Testing of Optical Line Systems for In-Span Interconnect).	Batelco and Licensed Operator
SDH System Confirmation*	Both parties are required to sign to confirm that the SDH system has been tested and meets the specified requirements.	Batelco and Licensed Operator
Routing advices issued to Access Provider and Access Seeker	Signalling and routing advices for the route are issued by Access Provider and sent out to the Access Seeker.	Access Provider
Circuit Provision and Databuild	The 2 Mbit/s sub-rate streams are provided and the data built.	Batelco and Licensed Operator
RFT Declared	The Interconnection route is declared to be RFT and a RFT certificate is issued to the Licensed Operator.	Batelco CSD
Testing	The Licensed Operator will have contacted the Batelco CSD to arrange when testing can take place. At the time when testing is due to start the operational teams in both Batelco and the Licensed Operator will contact each other and will jointly carry out the Interconnection tests as specified in Appendix 30 (Testing Procedures).	Batelco CSD
Check Test Results	The results of the Interconnection tests are checked by both Batelco and the Licensed Operator.	Batelco and Licensed Operator
Bring Into Service	Subject to satisfactory test results both parties will sign the RFS certificate. Once the RFS certificate has been signed off the circuits will be available for	Batelco CSD and Licensed Operator

Activity Name	Activity Descriptions	Owner
	use by the Licensed Operator. The bringing into service activities are described in paragraph Error! Reference source not found. of this Paragraph 5 (Bringing into Service).	

Annex 5B - Key Activities – CSI Link Service

Activity Name	Activity Descriptions	Owner
Access Seeker sends Firm Order to Access Provider	Access Seeker sends Capacity Order to Access Provider	Access Seeker
Order validation by both parties	The parties will validate the order against the agreed arrangements for the interconnect contained in the Technical Master Plan. An invalid order will be passed back to the Access Seeker and will not be progressed. Order validation will be way of the form in Appendix 21.	Batelco and Licensed Operator
Network Capacity Assigned	Batelco assigns intra building links for the 2 Mbit/s interconnect systems.	Batelco
Advise RFT Date	Batelco advises the Licensed Operator of the RFT date(s) for the order.	Batelco
Schedule Test Dates	Batelco and the Licensed Operator agree Operational Test Schedule for the order.	Batelco and Licensed Operator
SRAs issued to Batelco and Licensed Operator	Signalling and Routing Advice(s) are issued by Access Provider and sent to the Batelco and Licensed Operator. The form used in Appendix 23 shall be used to provide this advice.	Batelco and Licensed Operator
Circuit Provision and Databuild	The 2 Mbit/s interconnect systems are provided and the data built.	Batelco and Licensed Operator
RFT Declared	The Interconnect route is declared to be Ready For Test and a Ready for Test Certificate is issued to the Access Seeker.	Batelco
Testing	At the time when Testing is due to start the testing teams in both Batelco and the Licensed Operator will contact each other and then jointly carry out the Tests as specified in the relevant in Schedule 30.	Batelco and Licensed Operator
Bring Into Service	Subject to testing being completed satisfactorily both parties will sign the Ready for Service Certificate. Once the RFS Certificate has been signed, the circuits will be available for introduction to public service.	Batelco CSD and Licensed Operator

6. CESSATION OF CAPACITY

6.1 Introduction

This paragraph describes the provisioning activities required for the cessation of Interconnection Capacity on traffic routes between the Licensed Operator Network and the Batelco Network.

6.2 Procedures and Task Overview

6.2.1 Preliminary Planning

The need to cease capacity, as identified by analysis of Forecasts and Capacity Profiles, will be discussed at the technical review meeting forum.

6.2.2 Orders for the Cessation of Capacity

Capacity Orders for the cessation of Capacity will be provided by the Access Seeker to the Access Provider. An example of an order form is set out with explanatory notes in Appendix 26 to this Joint Working Manual (Capacity Order Form). The Access Provider will plan the work necessary to fulfil the order.

6.2.3 Provision of the Cessation of Capacity

The stages, key activities and activity descriptions for the provision of the cessation of Capacity are shown in Annex 6 to this Paragraph **Error! Reference source not found.** (Cessation of Interconnect Capacity).

Annex 6 - Cessation of Interconnect Capacity

Activity Name	Activity Descriptions	Owner
Access Seeker sends Capacity Order to Access Provider	The Access Seeker sends Capacity Order to Access Provider.	Access Seeker
Order validation by Access Provider.	Both parties will validate the order against the agreed arrangements for the Interconnection contained in the Technical Master Plan. An invalid order will be rejected and Access Provider will provide an explanation of the non-compliance.	Batelco and Licensed Operator
Routing advices issued to Access Provider and Access Seeker	Signalling and routing advices for the route are issued by Access Provider and sent out to the Access Seeker. The advice will be provided using the form in Appendix 23.	Access Provider
Databuild	The Licensed Operator and Batelco amend their databuild to reflect the cessation.	Batelco and Licensed Operator
Confirm with Access Seeker that Traffic removed	Access Provider seeks confirmation from Access Seeker that no traffic is carried on the Capacity.	Access Provider
Cease Capacity	The Capacity is ceased.	Access Provider
Issue Removal Certificate	When the circuit has been ceased a removal certificate is issued in the form of Appendix 22 (Interconnect Order Completion).	Batelco

7. LIAISON

In order to maintain effective communications between Batelco and the Licensed Operator, a contact register should be completed. An example of a form of contact register is set out in Appendix 31 this Joint Working Manual (**Contact Register**).

8. DICTIONARY

8.1 Definitions

In this Joint Working Manual, unless the context otherwise requires:

μF means micro Farad.

μs means microsecond.

2Mbit/s means 2048 kbit/s.

Access Provider means the supplier of a Service.

Access Seeker means the acquirer of a Service.

Add Drop Multiplexer means an SDH multiplexer which allows 2 Mbit/s streams to be inserted or removed from a Synchronous Transport Module stream.

Advance Capacity Order means part of the Capacity Profile which sets out the Capacity ordering intentions of the relevant party over the first 4 months of the Capacity Profile.

AIS means Alarm Indication Signal.

Batelco Carrier Services Division or Batelco CSD means the division of Batelco responsible for interconnection from time to time.

Batelco Switch Connection means the switch designated by Batelco as the switch closest to a Point of Interconnection. The Batelco Switch connection initially shall be the BTC Tandem IC1.

Batelco Network means the network described in Appendix 29.

BER means Bit Error Rate.

Build Level means the software and hardware combination reference given by the manufacturer of the switch to which the Build Level refers.

Capacity means the telecommunication capacity to be made available at an Interconnect Link.

Capacity Order means an order for Capacity using the form contained in Appendix 26.

Capacity Profile means a profile of future Capacity ordering intentions, as specified using the form contained in Appendix 20.

Capacity Re-arrangement means the re-use of Capacity on Interconnect Links previously provided by one party to the other, where in each case the Point of Interconnection and the buildings containing the switch connections of the providing party remain the same.

Carrier System means a point to point transmission facility whose sole purpose is to provide 2.048 Mbit/s Interconnection Links between an Access Provider circuit termination unit and an Access Seeker circuit termination unit. It incorporates the multiplexing and de-multiplexing of 2.048 Mbit/s bearer services.

Circuit means a telecommunications transmission circuit which has Capacity of one unit of 2.048 Mbit/s.

CRD means Completion Date.

CSI Link Service means the Service to establish an Interconnection Link more particularly described in the relevant Service Description.

Customer means an End User supplied by either Batelco or the Licensed Operator as appropriate.

dB means decibel.

dB_r means decibel relative to a stated level.

DC means Direct Current.

DDF means Digital Distribution Frame.

Emergency Call means a 999 or 112 Telephone Call handed over from the Licensed Operator Network to the Batelco Network.

Erlang means a unit used to denote the utilisation of a telecommunications Network.

ETSI means European Telecommunications Standards Institute.

ETSI-ISUP means the ISDN User Part defined by ETSI.

ETSI Standard means a standard published ETSI.

Final Test Report means the log of interconnection tests produced in accordance with this Joint Working Manual.

First Live Traffic Testing or **FLT** has the meaning given in Appendix 30.

Footway Box means apparatus housing a fibre splice for the purposes of In-Span Interconnect.

Forecast means a quantitative prediction made by the Access Seeker for the Services required from the Access Provider over an agreed period as required under [clause 15] of the Supply Terms and Paragraphs 2 and 4 of this Joint Working Manual (Forecasts and Capacity Profiles).

Individual Location Test or **ILT** has the meaning given in Appendix 30.

In-Span Interconnect Service means the service to establish an Interconnection Link more particularly described in the relevant Service Description.

Interconnection means interconnection of the Licensed Operator Network and the Batelco Network in accordance with this Joint Working Manual.

Interconnection Link means a link connecting the Batelco Switch Connection and a Licensed Operator Switch Connection passing through a Point of Interconnection.

ISDN means Integrated Services Digital Network.

ISI means an In-Span Interconnect.

ISUP means ISDN User Part.

ITU means International Telecommunications Union.

ITU Recommendation means a recommendation published by the ITU.

ITU-T means International Telecommunication Union – Telecommunications.

kbit/s means kilobit per second.

kHz means kilo Hertz.

Licensed Operator Switch Connection means a connection to a Licensed Operator switch.

Licensed Operator Network means the Network in Bahrain operated by Licensed Operator.

LR means Loudness Rating.

Mbit/s means Megabits per second.

MTP means Message Transfer Part.

Network Interworking Test or **NIT** has the meaning given in Appendix 30.

Interconnect Link means a Uni-directional 2.048 Mbit/s transmission facility within a Carrier System.

NCRS means Non Circuit Related Signalling.

NTP means Network Terminating Point.

OLR means Overall Loudness Rating.

Operational Field Trial has the meaning given in Appendix 30.

O and M means Operations and Maintenance.

OTDR means optical timer domain reflectometer.

PCM means pulse code modulation.

Point Code means the unique Batelco designation for a switch or other network element and has the format [xxx].

Point of Interconnection has the meaning given in the dictionary of the Supply Terms.

ppm means parts per million.

PRBS means Pseudo Random Binary Sequence.

PSTN means Public Switched Telephone Network.

Reference Interconnection Offer is the reference interconnection offer made by Batelco and has the meaning given in the dictionary of the Supply Terms in Part 1 of Annexure 10 to the Supply Terms.

RFS means Ready for Service.

RFT means Ready for Test.

RLR means Receive Loudness Rating.

SCCP means Signalling Connection Control Part.

SDH means Synchronous Digital Hierarchy.

SMS means Short Message Service.

SS7 means signalling system number seven.

STM-1 means a synchronous transfer module operating at 155 Mbit/s.

STMR means Sidetone Masking Rating.

Switch Connection means either a Batelco Switch Connection or a Licensed Operator Switch Connection.

Technical Master Plan means the plan created as a result of the meetings specified in paragraph 3 of this Joint Working Manual (Technical Specification).

8.2 Interpretation

In this Joint Working Manual, unless otherwise specified:

- (a) singular includes the plural and vice versa;
- (b) different grammatical forms of the same word have the corresponding meaning;
- (c) words of inclusion are not words of limitation;
- (d) the expression "person" includes a reference to a person, firm, corporation or other legal entity;
- (e) references to either party shall include its legitimate successors or assigns;
- (f) a reference to a paragraph, Annex, Appendix or section is a reference to a paragraph, Annex, Appendix or section forming part of this Joint Working Manual;

- (g) headings are used for convenience only and do not affect the interpretation of this Joint Working Manual.
- (h) Capitalised terms used in this Joint Working manual which are not defined are defined in the Dictionary.

I

APPENDICES

APPENDIX 1 - TECHNICAL SPECIFICATIONS

1. GENERAL

This appendix sets out the guidelines for network performance, technical specifications, interface standards, routing and switching principles and other technical matters for the implementation of this Joint Working Manual.

2. TRANSMISSION AND SYNCHRONISATION

Batelco and the Licensed Operator shall ensure that their respective Networks perform in accordance with the relevant specifications as they apply to the provision of Services pursuant to this Joint Working Manual.

3. INTERCONNECTION METHODS

Each Point of Interconnection established under this Joint Working Manual shall be established using, at the Licensed Operator's election, In-Span Interconnect Service or the CSI Link Service.

4. IN-SPAN INTERCONNECT ARCHITECTURE

In-Span Interconnect will be provided using SDH terminal equipment without the need for signal regeneration and in accordance with Appendix 2 (Specification of the Generic Electrical and Physical Interface).

The physical connection of SDH Interconnection between each party's Network shall be made in a Footway Box, or other mutually agreed location. For the avoidance of doubt, In-span Interconnection shall be made using fibre optic cable.

The specification of the cable to be used for In-Span Interconnect is set out in Appendix 10 (Optical Fibre Cable Performance Specification) and Appendix 11 of this Joint Working Manual (Optical Fibre Cable Specification). Each party shall supply, install and test the cable from its Network to the Footway Box.

Batelco shall arrange sufficient fibre optic cable to be available in the Footway Box for the Licensed Operator in the cable into its adjacent premises.

All work performed on Batelco's plant shall be performed to Batelco's standards by Batelco's approved contractors and under Batelco's supervision.

Commissioning and acceptance of any interconnecting cable shall be carried out jointly by both parties in accordance with the cable acceptance specification set out in Appendix 12 (Optical Fibre Acceptance Procedures).

Optical fibre cables shall be terminated at each end on an optical distribution frame or optical line terminating equipment. The optical line terminating equipment shall be connected to suitable multiplex equipment. The terminal equipment at each end of the Interconnect Link, including any necessary multiplex equipment, optical distribution frame and miscellaneous items shall be the responsibility of the respective Network owner. All outputs from the multiplex equipment shall conform to the Appendix 2 (Specification of the Generic Electrical and Physical Interface).

The Interconnect Link shall be jointly tested end to end using the procedures set out in Appendix 30 (**Testing Procedures**).

5. ROUTING AND ARCHITECTURE

Traffic routes shall be fully provided to carry only the traffic for which Capacity has been ordered in accordance with this Joint Working Manual.

Batelco and Licensed Operator shall exchange and agree traffic routing plans prior to the provision of the telecommunication services.

6. ROUTING PRINCIPLES

6.1 Responsibilities

Each party shall route the other party's traffic in accordance with the principle that routing within a party's Network shall be equivalent to the routing of similar types of traffic for the generality of such party's Customers.

The parties shall develop and apply network traffic management strategies and procedures (**NMC Rules**) to maintain customer service quality and to protect the parties' Networks as are appropriate. The NMC rules will be incorporated into this Joint Working manual as Appendix 32.

6.2 Interconnect Traffic Route Structure

The parties shall establish Interconnect Links to convey Telephone Calls between the Batelco Network and the Licensed Operator Network.

Interconnect Links shall have traffic routes such that traffic routes shall be established to convey only those traffic types for which a party has responsibility.

The party whose switch connection conveys the relevant Telephone Call to the other party's Network shall assign traffic streams (identified by destination) to a particular traffic route. Batelco and the Licensed Operator shall, advise each other which traffic streams are assigned to which traffic route. Unless otherwise agreed, each party shall use its reasonable endeavours to ensure that traffic is directed in accordance with the advice given to the other.

Where there is a traffic route to or from a Switch Connection and notification has been given by either party that the relevant Switch Connection is to be removed or capped then no additional Capacity shall be provided on that traffic route save that agreed in the Advance Capacity Order current on the date when notification was given.

6.3 Interconnect Routing Rules

6.3.1 Licensed Operator to Batelco traffic

The Licensed Operator may convey traffic streams in any combination of fully provided traffic routes from the Licensed Operator Switch Connection to the Batelco Gateway Switch only in accordance with agreed routing plans.

6.3.2 Batelco to Licensed Operator traffic

Batelco may convey traffic streams in any combination of fully provided traffic routes from the Batelco Gateway Switch to the Licensed Operator Switch Connection only in accordance with agreed routing plans.

6.4 Record of Arrangements

The parties shall record the physical arrangements and number ranges, or part thereof, for each of the traffic routes on an Interconnect Link. Information shall be provided in accordance with this Joint Working Manual and a record of these arrangements shall be maintained in the Technical Master Plan.

7. SIGNALLING

Batelco and the Licensed Operator shall each ensure that signalling arrangements between their respective Networks conform to the SS7 signalling protocols as defined in Appendix 4 (Specification of the Generic Signalling System for Interconnection).

Unless otherwise agreed, signalling links shall be carried in time slot 1 of a Circuit. If time slot 1 is not used for signalling, then time slot 1 may be not used for conveying Telephone Calls. Each Circuit which is required to carry signalling shall also be capable of conveying Telephone Calls.

Signalling links shall be carried in the first and second Circuit of the Interconnect Link.

At least one pair of signalling links (Signalling Link Set), each in a separate Circuit shall be used. A Signalling Link Set may be used to support:

- (a) up to 64 x 2 Mbit/s Interconnect Links where such Signalling Link Set is comprised of two Signalling Links; or
- (b) up to 128 x 2Mbit/s Interconnect Links where such Signalling Links, having Traffic Routes for which a party has responsibility; or
- (c) where the Signalling Link capability of equipment in either party's System or the signalling message profile resulting from the type of traffic associated with the Traffic Route supported by the Signalling Link Set is such that the number of Signalling Links specified in (a) or (b) above are not capable of supporting the number of 2Mbit/s Interconnect Links specified, then the parties shall agree in writing the number of 2Mbit/s Interconnect Links that may be supported by each pair of Signalling Links within the Signalling Link Set. If the parties fail to agree the number of 2Mbit/s Interconnect Links that may be supported by each pair of Signalling Links within the Signalling Link Set then either party may notify the other party in writing of a dispute, which is to be resolved in accordance with the Dispute Resolutions procedures.

Initial Interconnection is inclusive of a SS7 signalling link set which will accommodate up to 64 Circuit. Capacity above this will require a further signalling link.

Each 2Mbit/s Interconnect Link contains 30 x 64 traffic kbit/s circuits and may, if required contain a Signalling Link Set.

The Licensed Operator and Batelco shall operate switch connections in an uni-directional manner but switches shall be data-filled so as to be capable of operating in a bi-directional manner in the event of network management action.

In the event that the parties agree to operate a switch connection in a bi-directional manner, either switch may seize the free traffic channels and one or both switches shall clear the seizure and re-attempt the Telephone Call set-up.

In order to minimise the number of simultaneous traffic seizures, each switch shall search its traffic channels in the reverse sequence to the other switch. Unless otherwise agreed the Licensed Operator Switch Connection shall seize channels in descending order and the Batelco Gateway Switch shall seize channels in ascending order.

8. SWITCH TESTING

Testing procedures are set out in Appendix 30 of this Joint Working Manual (**Testing Procedures**).

Suggested time scales for testing are as follows:

- (a) ILT - up to 4 months;
- (b) NIT - 4 weeks;
- (c) First Live Traffic Testing - 2 weeks (including results validation); and
- (d) Operational Field Trial - 6 weeks.

Time scales specified above will be dependent on the new switch type, Licensed Operator's own test plan and the level of testing agreed.

9. NETWORK PERFORMANCE

Each party shall use all reasonable endeavours to manage its Network by taking real time network management actions agreed between the parties appropriate network management centres to protect the Networks in the event of national emergencies, system failures, mass calling events and any event having a similar impact on the Network.

Wherever possible advance warning should be given to the other party when a party becomes aware of a mass calling event likely to introduce higher than normal traffic levels across a particular traffic route.

Should either party (the "first party") fail to take appropriate network management actions in accordance with the paragraph above then the other party may in order to protect all or part of

its Network arrange to disconnect any traffic routes creating or helping to create such failure. Such action shall be notified to the first party prior to disconnection.

Technical review meetings should be held at intervals not greater than 120 days. The first such meeting will be no later than 120 days after the receipt of the first Capacity Profile.

The NMC Rules to be developed in accordance with paragraph 6.1 shall address:

- (a) call gapping;
- (b) trunk reservation and notification; and
- (c) mass calling; and
- (d) attack dialling.

10. NUMBERING

Both parties shall conform to the national and international numbering formats in place from time to time.

Both parties shall notify the other in writing giving details of new number ranges allocated to them and amendments to existing number ranges.

When conveying a Telephone Call to the other party's Network, each party shall convey to the other the complete number including the national and international trunk prefix.

Each party (the "first party") shall use its reasonable endeavours to notify the other party in writing, giving details of new number ranges allocated to the first party and amendments to or deletions of existing number ranges, in each case at least 29 working days prior to the bringing into service or deletion of such number ranges. Each party shall allocate numbers in order to align with the Bahrain Numbering Plan.

APPENDIX 2 – SPECIFICATION OF THE GENERIC ELECTRICAL AND PHYSICAL INTERFACE

1. GENERAL

This Appendix defines the physical and electrical characteristics of Interconnect Link, between the Batelco Network and the Licensed Operator Network.

All references to ITU Recommendations refer to the White Book unless otherwise indicated.

2. ELECTRICAL INTERFACE

The following paragraph shall apply to a 2Mbit/s interface using the coaxial pair option of ITU-T Recommendation G.703 entitled Physical/Electrical Characteristics of Hierarchical Digital Exchanges.

2.1 General Characteristics

These shall conform to section 6.1 of ITU-T Recommendation G703.

2.2 Specifications at the Output Ports

These shall conform to section 6.2 of ITU-T Recommendation G.703 (Table 6).

2.3 Specifications at the Input Ports

These shall conform to section 6.3 of ITU-T Recommendation G.703.

2.4 Earthing of screen

2.4.1 Output Ports

At output ports the cable screen shall be bonded to the equipment metalwork at the equipment boundary or as near as possible to it.

2.4.2 Input Ports

The input port cable screen shall be earthed via a capacitor (typically 0.1 μ F) to the equipment. Provision shall be also made at this point for providing a DC connection to earth. The equipment shall be set-up with the DC earth not connected.

A suitable ferrite tube ferrule should be threaded onto the cable so as to be located at a point between the bonding point and the equipment circuitry

2.5 Interference

The input ports shall tolerate, without error, interference from a non synchronous standard test signal (ITU-T Recommendation O.151- Error Performance Measuring Equipment for Digital Systems at the Primary Bit Rate and above) at a level 18dB lower than the wanted signal.

2.6 Jitter and Wander

Jitter and wander shall conform to ITU-T Recommendation G.823.

2.7 Batelco and Licensed Operator Network Synchronisation

The Batelco Network employs a caesium central master clock to maintain a co-operatively synchronised system within ITU-T recommended frequency limits.

3. LICENSED OPERATOR NETWORK SYNCHRONISATION

To ensure synchronisation with the Batelco Network, the Licensed Operator Network shall employ a synchronisation system which is time traceable to a source complying with the requirements of ETS 300 462-6 (ITU-T G.811).

The performance of digital clocks, which derive synchronisation, shall comply with the objective slip rate characteristics given in ETS 300 462 and ITU-T Recommendations G.811 and G.822 for the purpose of minimising timing perturbations in general and slip rates in particular.

3.1 Deriving synchronisation from the Batelco Network

If the Licensed Operator Network is to derive synchronisation from the Batelco Network it shall take its timing from Batelco nominated synchronisation feeds in a master/slave relationship.

Where suitable, the synchronisation feeds may be taken from 2Mbit/s Interconnection Links carrying traffic between the Batelco Switch Connection and Licensed Operator Switch Connection.

If the Licensed Operator switch is taking timing information from the Batelco Network via a 2 Mbit/s Interconnect Link which fails (i.e. AIS is detected) then it must meet the following requirements:

- (a) Switching synchronisation to an alternative 2Mbit/s Interconnect Link, if available.
- (b) If no such synchronisation is available, entering holdover mode and keeping within the limits of holdover operation specified in section 2.2.3 of ITU-T Recommendation G.812 (Holdover Operation).

4. FUNCTIONAL CHARACTERISTICS OF THE INTERFACE

Functional characteristics of the 2 Mbit/s interface shall be in accordance with ITU-T Recommendations G.704 (Synchronous Frame Structures used at Primary and Secondary Hierarchical Levels) and G.706 (Frame Alignment and Cyclic Redundancy Check (CRC) Procedures Relating To Basic Frame Structures Defined In Rec. G.704) with the following additions and clarifications:

4.1 Signalling

If time slot 1 is not required for signalling information, it must not be used as a traffic carrying channel within the Batelco Network.

Time slots used for signalling will be designed for a normal load of 0.2 Erlang and a maximum load of 0.4 Erlang following the guidelines of ETS 300 008.

4.2 Timeslot '0'

Chapter 2.3 of ITU-T Recommendation G.704 (Basic Frame Structure at 2048 kbit/s) applies. Bits 4-7 in time slot zero not containing the frame alignment signal should be set to "1". The use of bit 8 for the return direction shall be determined by Batelco at each location. On some systems bit 8 will be set to "1" in the go and return direction. On other systems when Batelco detects one or more errors in the frame alignment word, this bit 8, in the return TSO "not" word, will be set at a "1" state on two successive occasions; when no errors are detected bit 8 will be set to the "0" state. If possible, the Licensed Operator switch should make the same use of this bit 8, if not it should be tolerant to the sending of bit 8 in the return direction and set it to "0" in the go direction.

4.3 Alarm Indication Signal (AIS)

Under certain fault conditions AIS is used in the Batelco Network. AIS is indicated by a continuous stream of binary 1's. When transmitted, AIS is controlled by a free running 2048 kbit/s crystal oscillator (accuracy within ± 50 ppm).

The strategy for detecting the presence of AIS should be such that AIS is detectable, even in the presence of an error ratio of 1 in 1000. However, a signal with all bits except the frame alignment word in the '1'state, must not be mistaken as an AIS.

4.4 Channel Time Slot Encoding

The 64 kbit/s channel time slots comprising the 2048 kbit/s stream shall carry 'A' law encoded information as defined in ITU-T Recommendation G.711 (Pulse Code Modulation (PCM) Of Voice Frequencies).

The idle channel bit pattern transmitted over the Interconnect Link shall be compliant with section 2.12 of ITU-T Recommendation Q.522 (Bit Patterns Generated By The Exchange In Idle Channel Time slots).

5. SAFETY AND PROTECTION

5.1 Dangerous Voltages

In order to protect personnel and equipment on both sides of a Point of Interconnection, it is necessary to provide protection against the transmission of excessive voltage across the interface.

For equipment which uses or generates excessive voltages the interface shall be electrically isolated from those voltages.

5.2 Radiation Hazards

Where radio equipment is used, arrangements shall be made to protect all personnel from levels of radiation exceeding 1 milliwatt per square centimetre.

6. REFERENCES

The ETSI Standards and ITU-T Recommendations referred to in this Appendix are as follows:

ETSI Standards

ETS 300 462 Transmission and Multiplexing (TM); Generic requirements for synchronization networks

ETS 300 008 Integrated Services Digital Network (ISDN); Signalling System No. 7; Message Transfer (MTP) to support international interconnection; Part 2: Protocol Implementation Conformance Statement (PICS) proforma specification.

ITU-T Recommendations

G.703 Physical/Electrical Characteristics of Hierarchical Digital Exchanges

G.704 Synchronous Frame Structures used at Primary and Secondary Hierarchical Levels

G.706 Frame Alignment and Cyclic Redundancy Check (CRC) Procedures Relating To Basic Frame Structures Defined In Rec. G704

G.711 Pulse Code Modulation (PCM) Of Voice Frequencies.

G.811 International Connections Terminating on Synchronous Network Nodes

G.812 Timing Requirements of Slave Clocks suitable for use as Node Clocks in Synchronisation Networks

G.822 Controlled Slip Rate Objectives on an International Digital Connection

G.823 The Control of Jitter and Wander within Digital Networks Which are based on the 2048 kbit/s Hierarchy

O.151 Error Performance Measuring Equipment for Digital Systems At The Primary Bit Rate and Above

O.171 Timing Jitter Measuring Equipment for Digital Systems

Q.522 Section 2.12 Bit Patterns Generated By The Exchange In Idle Channel Time slots

Q.551 Transmission Characteristics of Digital Exchanges

APPENDIX 3 – SPECIFICATION OF THE GENERIC TRANSMISSION INTERFACE

1. GENERAL

This appendix sets out the transmission requirements and objectives to be met by Batelco and the Licensed Operator for the interconnection of the Batelco Network and Licensed Operator Network.

The requirements are based on the relevant ETSI Standards and ITU Recommendations.

References to Global Systems for Mobile (**GSM**) are based upon ETS 300 540 GSM Phase 2.

End to end requirements involve the performance of Customer equipment which is outside Batelco and the Operators control.

Customer network as referred to throughout this appendix typically consist of at least one item of Customer Premises Equipment (CPE) situated beyond the Network Terminating Point (NTP).

Where this appendix sets out matters that the parties endeavour to agree, and agreement is not reached, such matters shall be disputes.

2. RESPONSIBILITIES

The responsibility for overall transmission quality is held by the party selected by the Customer to carry the Telephone Call.

If the overall transmission quality for a Telephone Call cannot be met because either party is unable to comply with the reasonable requests of the other party, then neither party will be obliged to convey the Telephone Call.

3. RELEVANT PARAMETERS

Overall performance is affected by the following parameters:

Overall loss

Echo and Stability

Quantising distortion

Coding standards

Attenuation distortion

Group delay distortion

Sidetone loss

Crosstalk

Errors

Jitter and wander

Batelco and the Licensed Operator shall endeavour to achieve the requirements and objectives for overall loss, delay, echo loss, quantising distortion, and coding standards given in this appendix. Batelco and the Licensed Operator shall each plan in accordance with the guidance given for the remaining parameters listed above.

It should be noted that for some parameters the CPE may have a significant effect on the end to end performance.

4. OVERALL TRANSMISSION LOSS

4.1 Loudness Rating (LR)

The limits for overall loss expressed in terms of Loudness Ratings (LR) are defined in ITU-T Recommendation P. 76 (Blue book November 1989).

5. APPORTIONMENT OF OVERALL LOUDNESS RATING (OLR)

5.1 End to End Requirements

Batelco and the Licensed Operator shall endeavour to:

- (a) avoid connections which exceed the ITU-T Recommendations limiting OLR value of 29dB; and
- (b) minimise the range of different transmission levels experienced by any one Customer.

5.2 GSM Loudness Control

Cellular network operators may utilise digital level control in the mobile switched network to control Send Loudness Rating (SLR) and Receive Loudness Rating (RLR) values.

5.3 RLR and Receive GSM Volume Control

The use of any Customer controlled receive volume control shall not decrease (i.e. make more sensitive) the RLR, by more than 10 dB for planning purposes.

6. ECHO LOSS

Batelco and the Licensed Operator shall seek to meet the design objective for echo loss (as defined in ITU-T Recommendation G122) presented at the Batelco Switch Connection and the Licensed Operator Switch Connection (as appropriate) with equal relative levels for both directions of transmission of 20dB, with no connections being less than 15dB for practical implementation.

CPE connected via a 2-wire interface can have significant effect on echo losses. For planning purposes Batelco and the Licensed Operator shall assume that CPE will present an impedance of 600 ohms.

CPE and customer networks are likely to determine the largest part of echo losses in the case of 4-wire connection to the Batelco and the Licensed Operator Networks. For planning purposes Batelco and the Licensed Operator shall assume that the CPE meets a 20dB echo.

6.1 GSM Echo Loss

The echo loss under operational conditions for a GSM based system shall be at least 46 dB referred to the switch connection with any Customer volume control set to its maximum output (i.e. loudest) position. ETS 300 540 provides further information related to echo loss.

ITU-T Recommendation G.165 provides guidance for the performance of echo control devices when switched into a connection. ITU-T Recommendations G151 and G.473 refer.

6.2 Echo Control - GSM

The GSM system shall provide echo protection as set out in ETS 300 540.

7. STABILITY LOSS

CPE connected via a 2-wire interface may have a significant effect on stability loss. For planning purposes Batelco and the Licensed Operator shall assume the CPE may present either open circuit or short circuit conditions at a 2-wire NTP.

CPE and Customer networks are likely to largely determine the stability losses in the case of 4-wire connection to the Batelco Network and the Licensed Operator Network. For planning purposes Batelco and the Licensed Operator shall assume that the CPE meets a 6dB stability loss requirement.

It is recognised by the parties that stability losses of less than 6 dB could cause oscillation.

8. QUANTISING DISTORTION

For planning purposes Batelco and the Licensed Operator shall assume that Customer networks do not introduce more than 2 qdu.

9. CODING STANDARDS

At a digital interface it is a requirement that analogue information shall be encoded using the 8bit, A-law characteristic.

10. NOISE

The power in any individual tone should be 10dB less than the psophometric noise power in the circuit (ITU-T Recommendation P.11).

The following ITU-T Recommendations shall be complied with to give appropriate limits:

Digital Exchanges - Recommendations Q.551 and Q.554

PCM line systems - Recommendation G.712

GSM systems - ETS 300 540

The limits in ITU-T Recommendation G.123 are of particular importance as they control the level of noise on International Calls.

11. ATTENUATION DISTORTION

In order to adequately control attenuation distortion each component of the connection shall have a suitable distortion limit. The following ITU-T Recommendations apply:

Digital Exchanges - Recommendations Q.551 and Q.554

Digital Line Systems - Recommendation G.712

12. GROUP DELAY DISTORTION

The following ITU-T Recommendations give suitable limits for the group delay distortion introduced by line transmission systems and coding processes in digital exchanges:

Digital Exchanges - Recommendations Q.551 and Q.554

Digital Line Systems - Recommendation G.712

13. SIDETONE MASKING RATING - TELEPHONY CUSTOMER TO BATELCO PSTN.

The Sidetone Masking Rating (STMR) for telephony CPE connected to a Batelco Network Terminating Point shall nominally be taken as 7 dB for planning purposes.

13.1 Sidetone Masking Rating Batelco PSTN to GSM

The STMR for telephony CPE allowing users to gain access through the GSM system shall be nominally taken as outlined in ETS 300 540 for STMR.

14. ERROR PERFORMANCE

Error performance of digital networks is of key importance as it determines the end to end performance of both end to end digital services and analogue services supported by the Batelco Network and Licensed Operator Network.

The allocation principles of ITU-T Recommendation G.821 shall be used when determining the error for individual transmission systems.

15. NON SPEECH LEVELS

The use of any non-speech signals within an established Telephone Call, or during the phase of Telephone Call set-up or clear down, for such purposes as signalling (e.g. DTMF) shall be based upon a 0dB_r interface.

Interfaces that are not taken as a 0 dB_r point shall be planned as if they were a 0 dB_r for purposes of realising interconnection between the Batelco Network and a GSM network.

16. GSM HANDSET SENSITIVITY/FREQUENCY CHARACTERISTICS

The GSM network shall provide a performance in accordance with ETS 300 540.

17. REFERENCES

The ITU-T Recommendations and ETSI Standards referred to in this Appendix are as follows:

ITU-T Recommendations

G.123 Circuit Noise In National Circuits

G.165 Echo cancellers

G.712 Performance characteristics of PCM channels between 4-wire interfaces at voice frequencies

P.11 Effect of Transmission Impairments

P.76 Determination of Loudness rating; Fundamental principles

Q.551 Transmission characteristics of digital exchanges

Q.554 Transmission characteristics at digital interfaces of a digital Exchange

ETSI Standards

ETS 300 540 GSM Phase 2

APPENDIX 4 – SPECIFICATION OF THE GENERIC SIGNALLING SYSTEM FOR INTERCONNECTION

1. OVERVIEW

The ITU-T common channel signalling system number seven (SS7) shall be used as the signalling system for the conveyance of Telephone Calls between the Licensed Operator Network and the Batelco Network.

Batelco and the Licensed Operator shall support ISDN User Part (ISUP) and Message Transfer Part (**MTP**) on each Interconnect Link. The user parts at each end of the signalling link shall be compatible.

The conveyance of PSTN and ISDN calls between the Licensed Operator Network and the Batelco Network must use MTP and ISUP, unless otherwise available and agreed between the Licensed Operator and Batelco.

For the conveyance of connectionless services (ie. services such as SMS which do not utilise a circuit) in support of mobile telephony, the Batelco Network and Licensed Operator Network may agree to use the SCCP and MTP.

2. PARTS OF SIGNALLING SYSTEM NO.7

2.1 Message Transfer Part

The Batelco Network and Licensed Operator Network when interconnected in the signalling domain shall comply with the specification of the SS7 MTP as defined in ITU-T Recommendation Q.762.

2.2 User Part

The Batelco Network and the Licensed Operator Network shall comply with ITU-T Recommendations Q.761 - Q.764 (inclusive).

2.3 Signalling Connection Control Part

Where the Batelco Network and a Licensed Operator GSM Network have agreed the support of non circuit related signalling services to enable GSM telephony users to have GSM roaming services, they shall comply with connectionless signalling protocols of the signalling connection control part as defined in ITU-T recommendations Q.711 - Q.714 (inclusive).

3. INTERWORKING

Except as provided in this paragraph, the Licensed Operator shall not interwork with Batelco using SCCP except to the minimum extent necessary to provide or acquire services in accordance with the Supply Terms.

The Licensed Operator and Batelco shall interwork signalling systems where the conveyance of the service or feature defined is compatible with ISUP.

Batelco remains responsible for the conveyance of signalling messages within the Batelco Network. Batelco can have no responsibility or liability for the acts or omissions of any third party telecommunications operator or overseas administration in respect of any signalling message handed over to or received from such third party. Batelco cannot guarantee that all services and features that transit the Batelco Network will interwork satisfactorily end to end.

4. TESTING

The Licensed Operator and Batelco shall confirm in writing that their implementation conforms to the relevant specifications and identify any deviations from that specification to be agreed between the parties before Batelco shall be obliged to convey SS7 signalling messages.

Batelco and the Licensed Operator agree to test the SS7 signalling interface in accordance with Appendix 30 (**Testing Procedures**). The testing shall be completed to both parties' satisfaction before Batelco shall be obliged to convey SS7 signalling messages.

Where the Licensed Operator or Batelco enhance the interface by adding a service or feature after interconnection has been provided, the parties shall inform each other, provide details of the changes and agree any additional testing that may be deemed necessary.

5. REFERENCES

The ITU-T Recommendations referred to in this Appendix are as follows:

ITU-T Q.711 Functional description of the signalling connection control part

ITU-T Q.712 Definition and function of SCCP messages

ITU-T Q.713 SCCP format and codes

ITU-T Q.714 Signalling connection control part procedures

ITU-T Q.761 Functional description of the ISDN user part of signalling system No. 7

ITU-T Q.762 General function of messages and signals

ITU-T Q.763 Formats and codes

ITU-T Q.764 Signalling procedures

APPENDIX 5 – GSM SHORT MESSAGE SERVICE

1. INTRODUCTION

In the event that GSM SMS messages form part of a Service Description, then the provisions of this Appendix will apply.

For the avoidance of doubt SMS delivery is only for termination on a GSM network (wherever originated). The GSM network is either the Batelco GSM network or the Licensed Operator's GSM network.

SMS will be implemented using 64 kbit/s interconnections between the SMS centres of Batelco and the Licensed Operator.

2. SPECIFICATIONS

The SMS will comply with GSM 04.11 version 7.0.0 Release 1998 and GSM 03.40 version 7.4.0 Release 1998 as set out in ETS 100 942 V7.0.0 and ETS 100 901 V7.4.0 (1999-12) respectively.

3. OBLIGATIONS

The SMS service is operated on a "bill and keep" basis. In general, GSM operators charge users for the origination of GSM SMS messages and not termination. Batelco and Licensed Operator must establish a reporting system that allows each party to be assured that all billable SMS messages have been appropriately recorded by each party.

4. REFERENCES

The ETSI Standards referred to in this Appendix are as follows:

ETS 100 942 V7.0.0 "Digital cellular telecommunications system (Phase 2+) - Point-to-Point (PP) Short Message Service (SMS) support on mobile radio interface"

ETS 100 901 V7.4.0 (1999-12) "Digital cellular telecommunications system (Phase 2+) - Technical realisation of the Short Message Service (SMS)"

APPENDIX 6 – FOOTWAY BOX ENGINEERING DRAWING

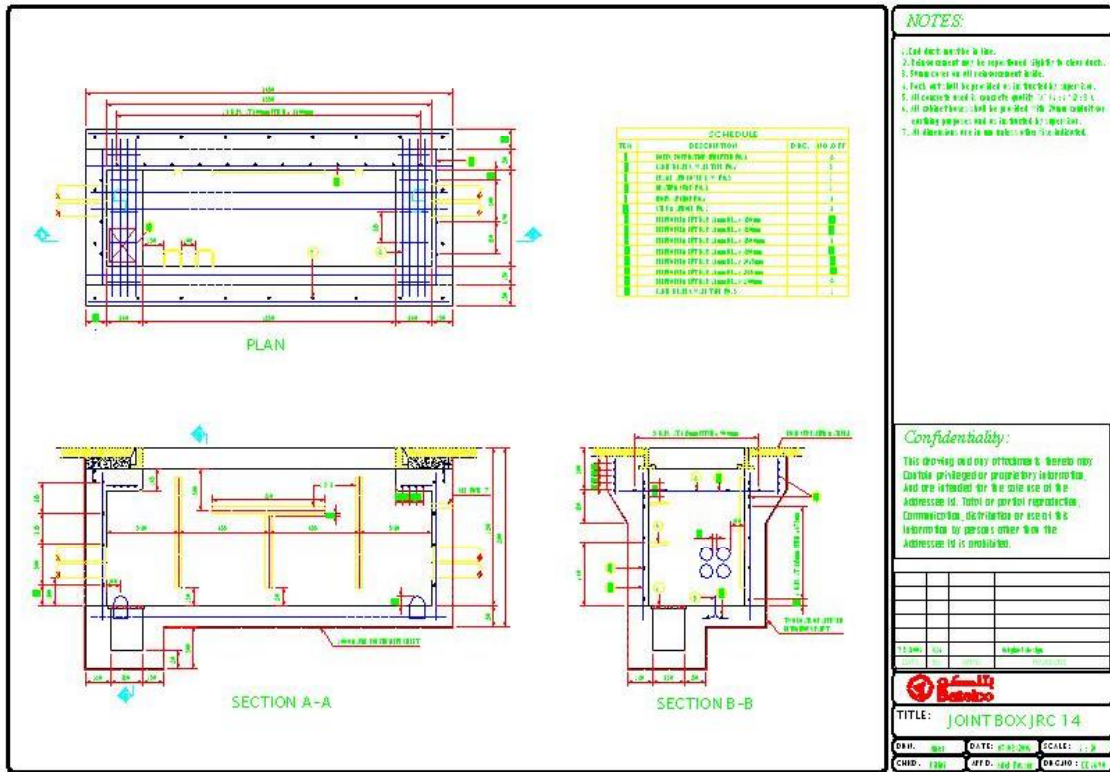

APPENDIX 7 – LIST OF SWITCH BUILDS AND PLATFORMS

This list is of the switches used in the Batelco Network and their Build Levels. These switches have not been used for interconnection.

Switch	Build	Use
NEAX61E (OCHS)	62-581-10	Operator service
AXE 10 (SCP)	TG5-AS57	PSTN IN
AXE 10 (TS3)	TG5-AS57	International
AXE 10 (S4)	TG5-AS57	International
AXE 10 (TS1)	TG5-AS57	Transit
AXE 10 (TS2)	TG5-AS57	Transit
AXE 10 (S1)	Local 7.0-AS56	Local
AXE 10 (S2)	Local 7.0-AS56	Local
AXE 10 (S3)	Local 7.0-AS56	Local
AXE 10 (S7)	Local 7.0-AS56	Local
E10 (S5)	R24	Local
E10B (S6)	R24	Local
E10B (S8)	R24	Local
CME (MSC1)	EMA-6	Mobile
CME (MSC2)	EMA-6	Mobile
CME (MSC3)	EMA-6	Mobile
CME (MSCG1)	EMA-6	Mobile
CME (MSCG2)	EMA-6	Mobile
AXE 10 (IC1)	TG5-AS57	Switch Connection

APPENDIX 8 – TRANSMISSION SYSTEMS FOR INTERCONNECT LINKS

The terminal transmission equipment at each end of a line system must be compatible for SDH working. The following STM-1 Add Drop Multiplexer are used in the Batelco Network:

- (a) Marconi Add Drop Multiplexer: MSH11, MSH11C, MSH11CP, MSH41, 51C; and
- (b) Marconi Add Digital Cross Connects: MSH80, MSH91

The use of other STM-1 Add Drop Multiplexer is not precluded but appropriate successful interworking/compatibility trials will be necessary before interconnection could be completed and brought into service. Batelco, acting reasonably and consistently with Appendix 30 of this Joint Working Manual (**Testing Procedures**) will determine these tests. The tests must be completed before an order for Interconnection Link is placed.

APPENDIX 9 – TRIBUTARY ASSIGNMENT/ALLOCATION FORMS

SDH Tributary Allocation Table

In-Span Point of Interconnection: _____

Transmission System Designation: _____

Tributary Allocations:

Link Designation	From	To	Direction	Tributary Card Allocation	Batelco Channel Number	Licensed Operator Channel Number

Submitted on
 behalf of [insert
 name of Access
 Seeker]

Agreed on behalf
 of [insert name of
 Access Provider] _____

Signed _____ **Signed** _____

Name _____ **Name** _____

Date _____ **Date** _____

Issue number: _____

APPENDIX 10 – OPTICAL FIBRE CABLE PERFORMANCE SPECIFICATION

Batelco specification BTC/1010/FIBRE

Bahrain Telecommunications Company BSC

SPECIFICATION BTC/1010/FIBRE

For

OPTICAL FIBRE - SINGLE MODE

(ISSUE-3 January 2003)

This specification outlines the requirements for single mode optical fibre for use in the construction of conventional cables suitable for use within the Batelco network. The fibre shall be of a nominal step-index, matched cladding design that has a dispersion minimum in the 1310nm region. The transmission performance is specified across a wavelength range from 1260nm to 1580nm.

1. SCOPE

This specification outlines the requirements for single mode optical fibre for use in the construction of conventional cables suitable for use within the Batelco network.

The transmission performance is specified across a wavelength range from 1260nm to 1580nm, the definitions and performance as detailed in ITU-T recommendation G.652 single-mode optical fibre also apply.

The optical fibre parameters shall be measured in accordance with the ITU-T recommendation G.650 Definition and test methods for the relevant parameters of single-mode fibres.

2. REFRACTIVE INDEX CHARACTERISTICS

2.1 Fibre Refractive Index Profile

Measurement Variables

Wavelength = 633nm.

Linewidth ≤ 5 nm.

The refractive index profile of the fibre shall be of a nominal step-index matched-cladding design. If any part of the inner cladding refractive index is different from the outermost 20 μ m of any radii on the fibre cross-section, the following requirements shall be satisfied by the inner-cladding region:

- (a) It shall be circularly symmetric around the core;
- (b) The difference between the index, n_1 . of the inner cladding region and the index

n_0 . of the outermost 20 μ m shall lie within the limits:-

$$+ 0.00005 \geq n_1 - n_0 \geq - 0.00040$$

2.2 Fibre Group Index

Measurement Variables

Wavelength = 1310 (± 10)nm and 1550 (± 10)nm.

Linewidth ≤ 5 nm.

Length of test fibre ≥ 1 km.

The value of effective refractive indices at 1310 nm and 1550 nm shall be provided.

2.3 Coating Refractive Index

The refractive index of the coating, n_c and the refractive index of the fibre cladding, n_0 shall be related as follows:

$$n_0 < n_c < 1.1 \times n_0$$

Where the coating is composed of more than one layer, the n_c shall refer to the inner layer. It is desirable for the outer coating layer to have a refractive index that exceeds n_c . The resin manufacturer's data shall be acceptable for this purpose.

3. GEOMETRICAL CHARACTERISTICS

3.1 Fibre

Measurement Variables

Length of test fibre ≥ 1 m.

Cladding edge threshold level = 50%

Calculation Ellipse Method

3.1.1 Cladding Diameter

The cladding diameter shall be 125 (± 2) μ m

3.1.2 Core / Cladding concentricity Error

The core / cladding concentricity error shall not exceed $0.7\mu\text{m}$.

3.1.3 Non-Circularity

The cladding non-circularity shall not exceed 2%.

3.2 Coating

3.2.1 Primary Coating

Measurement Variables

Minimum number of angular positions = 6

Minimum number of test samples = 10

(a) Coating Diameter

The diameter of the primary coating, excluding any colouring layers, shall be $245 \pm 10 \mu\text{m}$.

(b) Fibre cladding /Coating concentricity error

The fibre/primary coating concentricity error shall not exceed $10\mu\text{m}$.

(c) Coating non-circularity

The primary coating non-circularity shall not exceed 6%.

3.2.2 Secondary Coating

The diameter of the secondary coating shall be $800 \pm 50\mu\text{m}$.

4. TRANSMISSION CHARACTERISTICS

4.1 Mode Field Diameter

Measurement Variables

Wavelength = 1310 (± 5)nm.

Linewidth ≤ 5 nm.

Scan half-angle $\geq 25^\circ$

The mode field diameter shall be between the limit 8.8 μ m to 9.6 μ m.

4.2 Mode Cut-off Wavelength

The cut-off wavelength requirements detailed in Table 1 shall be met.

The cut-off value for external and internal fibres may be predicted from a measurement using the fibre configuration for category C (or vice versa). The relationship between the two configurations shall ensure that the predicted value is higher than the actual value with a probability of 95% or greater.

The form of the correlation shall be stated and shall be demonstrated.

Note: The conditions for external and internal fibres are an alternative configuration as permitted by IEC 60793-1-C7 § 23.4

Fibre Category	External	Internal	Patchcord
Wavelength range(nm)	1100 - 1400		
Linewidth (nm)	≤ 5		
Wavelength step size (nm)	≤ 5		
Mandrel diameter (mm)	80		280
Number of turns	2		1
Length of test fibre (m)	$\cong 2$		$\cong 2$
Maximum cut-off wavelength (nm)	≤ 1260		≤ 1250

Table 1: Measurement Conditions and Requirements For Cut-off Wavelength

4.3 Chromatic Dispersion

Measurement Variables

Wavelength range = 1260 - 1360nm and 1500 - 1600nm.

Linewidth $\leq 5\text{nm}$.

Wavelength step size $\leq 10\text{nm}$.

Length of test fibre $\geq 2\text{km}$.

Dispersion function: $D(\lambda) = S_0 / 4 [\lambda - \lambda_0^4 / \lambda^3]$

Where:

λ = wavelength;

$D(\lambda)$ = total dispersion;

λ^0 = wavelength of zero dispersion;

S^0 = slope of $D(\lambda)$ at $\lambda = \lambda^0$.

4.3.1 Slope at Wavelength of Zero Dispersion

The slope of total dispersion as a function of wavelength shall not exceed $0.093\text{ps}\cdot\text{nm}^{-2}\cdot\text{km}^{-1}$ at the wavelength of zero dispersion.

4.3.2 Magnitude of Chromatic Dispersion

The dispersion requirements of Table 2 shall be met.

Wavelength Range (nm)	Magnitude of chromatic dispersion (ps • nm ⁻¹ • km ⁻¹)
1290-1340	≤ 3.0
1260-1360	≤ 7.0
1480-1580	≤ 20.0

Table 2: Requirement of Maximum Chromatic Dispersion

4.4 Polarisation Mode Dispersion

Measurement Variables

Length of test fibre ≥ 1 km

Number of test samples >25 (1 per perform)

The PMD coefficient for production fibre shall be ≤ 0.3 ps/km^{0.5}. The supplier shall demonstrate the confidence level to which this requirement is satisfied, based on the sampling regime and the number of test samples.

4.5 Attenuation

4.5.1 Attenuation Coefficient

Measurement Variables

Wavelength range = 1260 - 1650nm.

Linewidth ≤ 5 nm.

Wavelength step size ≤ 5 nm.

The attenuation coefficient shall be met over the wavelength ranges defined in Table 3. In addition the manufacturer shall indicate the maximum attenuation at 1600 nm, 1625 nm and 1650 nm.

Range (nm)	Attenuation coefficient (dB km ⁻¹)
1260-1360	≤ 0.46
1290-1340	≤ 0.40
1360-1430	≤ 1.50
1430-1480	≤ 0.40
1480-1580	≤ 0.30

Table 3: Attenuation Windows

4.5.2 Attenuation Coefficient Uniformity

Measurement Variables

Wavelength = 1310 (± 20)nm and 1550 (± 20)nm.

Distance resolution ≤ 200 m, (in silica fibres, relates to pulse width $\leq 1\mu$ s).

(a) a. Local variations

The local attenuation coefficient shall not have point discontinuities in excess of 0.1dB.

(b) b. Extended variations

For fibre lengths in excess of 1km, the attenuation coefficients of contiguous 1km lengths shall not vary by more than 0.1dB/km.

4.5.3 Macro-Bending Performance

The macrobending requirements detailed in Table 4 shall be met.

Bend Loss may be described as a function of the MAC value (= mode field diameter/ fibre cut-off wavelength). The maximum available MAC value that does not exceed each of the requirements (to 95% confidence or better) in Table 4 shall be demonstrated. Figure 1 illustrates one possible method.

Fibre Category	External	Internal / Patchcords
Wavelength (nm)	1580	
Linewidth (nm)	≤ 5	
Mandrel diameter (mm)	60	40
Number of turns	100	15

Maximum bend loss (dB)	≤0.20	≤0.50
Additional information required for each category	Maximum permitted MAC value, together with the bend loss at this MAC value at 1600nm, 1625 nm and 1650 nm.	

Table 4: The Measurement Conditions For Macrobend Loss

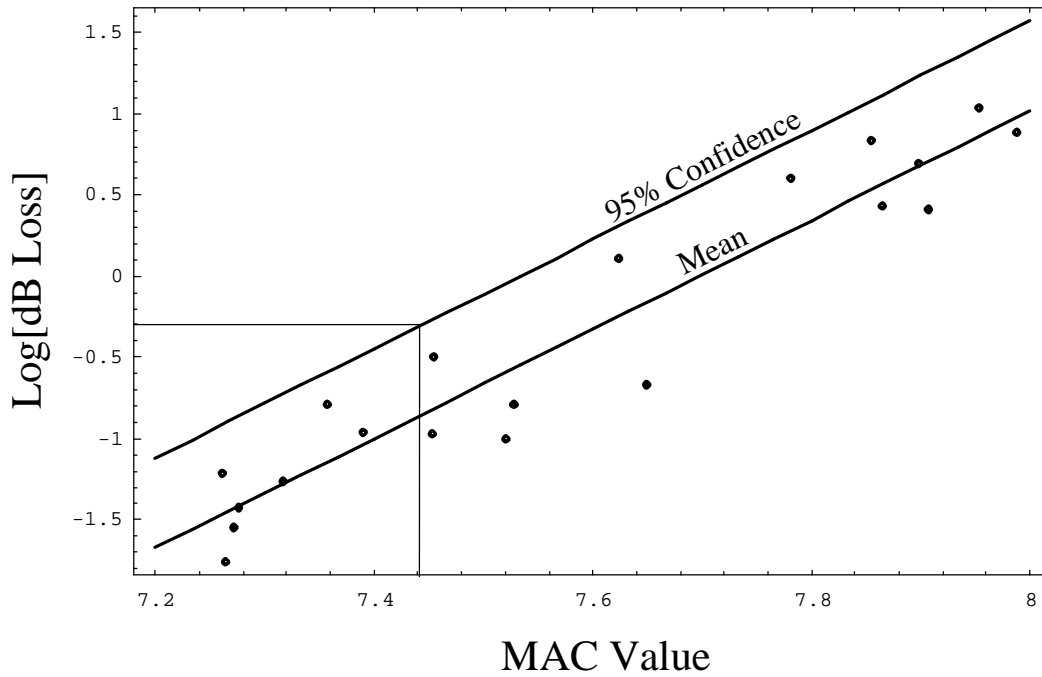

Figure 1. Relationship Between MAC Value and Macrobend Loss.

Figure 1 is an example of a plot of Log [dB Loss] versus MAC value for 20 simulated fibres of higher bend sensitivity. For fibres on the 95% confidence contour, there is only a 5% probability that the actual loss will exceed the predicted loss. In this illustration the 0.5 dB loss maximum for internal fibres is met for a MAC value of 7.44 or less.

5. MECHANICAL & ENVIRONMENTAL CHARACTERISTICS

To meet the requirement described in the particular cable specification being produced.

6. REFERENCES

ITU-T G.652 Characteristics of single mode optical fibre.

ITU-T G.650 Definition and test methods for single-mode fibres.

Note:-

Reference in this specification to any document listed above means, in any tender or contract, the edition any amendments current at the date of such tender or contract.

If any document has been superseded by another document, then the edition of the superseding document current at that date shall apply.

End of Specification

Issued by:

Manager of Access Network Development

Bahrain Telecommunications Co.

P. O. Box 14

Manama

Bahrain

Tel : 00973 884244

Fax : 00973 612999

Email : xa@btc.com.bh

SPECIFICATION BTC/1010/FIBRE

7. (AMENDMENTS FROM ISSUE 1 TO ISSUE 3)

Clause 1:

Reference to ITU-T recommendation G.652 single mode optical fibre and ITU-T recommendation G.650 Definition and test methods for the relevant parameters of single-mode fibre.

7.1 Clauses 2.1, 3.1.2, 3.1.3, 3.2.2, 4.1, 4.2, 4.3, 4.3.2, 4.5.1, 4.5.2, 4.5.3:

Clauses enhanced on requirements in ITU-T recommendation G.652 single mode optical fibre.

Clauses 4.4, 7:

New clause added and enhanced on requirements in ITU-T recommendation G.652 single mode optical fibre.

Clauses 2.2, 3.1, 6:

Reference to ITU-T recommendation G.652 single mode optical fibre and ITU-T recommendation G.650 Definition and test methods for the relevant parameters of single-mode fibre.

7.2 Clause 5:

To meet the requirement described in the particular cable specification being produced

APPENDIX 11 – OPTICAL FIBRE CABLE SPECIFICATION

Batelco specification BTC/1011/FIBRE

Bahrain Telecommunications Company BSC

SPECIFICATION BTC/1011/FIBRE

For

CABLE OPTICAL FIBRE

OUTDOOR, LOOSE TUBE, AIR SPACED

(ISSUE-3 January 2003)

This specification outlines the requirements for a pressurised single mode, optical fibre cable suitable for external use with loose tube construction of 8 fibres in each tube and fibre count of 8 to 96 fibres per cable, with a non-metallic central strength member and 3 copper pairs.

1. SCOPE

This specification outlines the requirements for a single mode, optical fibre air spaced cable suitable for external use with loose tube construction of 8 fibres in each tube and fibre count of 8 to 96 fibres per cable, with a non-metallic central strength member and 3 copper pairs. The cable will be pressurised after installation.

2. OPTICAL FIBRE

The optical fibres shall comply in design and construction to specification BTC/1010/FIBRE.

3. POLYETHYLENE SHEATH AND MOISTURE BARRIER

The polyethylene sheath and moisture barrier are to be in accordance with specification BTC/1961/SHEATH. The polyethylene material used for the sheath shall be in accordance with BS6234 (type 03C) and shall be coloured black.

4. CABLE DESIGN

The optical fibre cable shall contain single mode optical fibres to specification BTC/1010/FIBRE within polymer loose tubes stranded together with dummy filler tubes and three polyethylene insulated copper pairs of 0.6mm diameter in one or two layers around a non-metallic central strength member bound with tapes and an aluminium moisture barrier. The entire cable shall be enclosed within a black polyethylene sheath.

The manufacturer will have the choice in the design of the cable. However, such a design shall take into account current installation practices and environmental conditions the cable will experience.

In the event of an order, the manufacturer shall provide full details of the cable design and construction being offered complete with dimensioned target diagram, technical specification and test procedures to be adopted both during and after manufacture.

4.1 The Loose Tube

The polymer loose tubes shall contain 8 fibres depending on the specific requirement of the cable and in accordance with Table 1. The supplier shall provide, upon receipt of

an order and prior to cable manufacture a target diagram indicating the structure / viscosity compound and number of fibres per tube.

Each loose tube shall have a nominal external diameter as indicated in Table 1. There shall be no more than 8 fibres with colour coded primary coating within each jelly filled loose tubes.

4.2 Fibre and Loose Tube Identification

Identification of the fibres within each tube shall be by the use of the colour code as shown in Table 2. The identification of each tube shall be by marker / reference system as detailed in Table 3. Alternatively each tube shall be numbered sequentially.

4.3 Dummy Filler Tubes

Where appropriate, cables may contain dummy filler tubes, they shall be coloured yellow except where they may be used as an alternative for tube identification. Dummy filler tubes shall be of a suitable material.

4.4 Tapes

The tapes, shall be polyester, polypropylene, paper or other suitable approved material. Any colour or markings shall be readily identifiable. Neither the type colour or the markings shall be adversely effected by the cable constituents.

4.5 Identification

The name of the manufacturer and year of manufacture shall be indelibly marked at intervals of not more than 100mm, either on a paper tape or on the outer wrappings of the insulating paper. If a marked tape is used then it shall be laid either under the outer wrappings or under the sheath.

4.6 Cable Sheath

The cable sheath construction shall be in accordance with Batelco specification BTC/1961/SHEATH. The sheath material shall be in accordance with BS6234 (type 03C) and shall be coloured black.

4.7 Diameter

The external diameter of the cable is to be specified, but should not be greater than the measurements in Table 1.

4.8 Centra Strength Member

The central strength member diameter shall be as specified in Table 1.

4.9 Cable Weight

The overall cable weight shall be as specified in Table 1.

4.10 Bending Radius

The cable shall have a minimum bending radius of 12 x the external cable diameter during installation and 6 x external cable diameter during operation.

4.11 Operating Temperature

The operating temperature of the cable should be within the range -20°C & +60°C.

4.12 Cable Marking

The cable sheath shall be marked in accordance with specification BTC/1961/SHEATH.

Table 1: Dimensions, Weight and Length of Cables

No. of fibres	No. of tubes	No of Fibres per Tube	Max O.D. of Tubes (mm)	Max O.D. of Cable (mm)	Max Dia of Central Strength Member	Max Cable Weight (Kg/Km)	Standard Length (Km)
8	1	8	2.7	15	5	170	4
24	3	8	2.7	15	5	170	4
48	6	8	2.7	20	5	170	2
96	12	8	2.7	20	5	270	2

Table 2: Fibre Identification

Fibre No.	Colour Code
1	Blue
2	Orange
3	Green
4	Red
5	Gray
6	Yellow
7	Brown
8	Violet

Table 3: Loose Tube Identification

Loose Tube/Dummy Filler.	Colour Code
First Tube	Red
Intermediate Tube	Natural
Last Tube	Green
Dummy Fillers	Yellow

5. COPPER CONDUCTORS

- (a) Each conductor in the cable shall consist of a solid wire of standard annealed-copper, smoothly drawn, circular in section, uniform in quality, free from defects, and having a diameter of 0.6 mm.
- (b) A test piece of the conductor, taken from the completed cable shall, when slowly and steadily stretched, give a minimum elongation of 15%. A gauge length of 250mm shall be used, and the elongation shall be measured on the gauge length after the fractured ends have been fitted together.

- (c) Joints in the conductor shall be kept to a minimum and shall fulfil the following condition:-

The ultimate tensile force of a 250 mm length of conductor containing a joint shall be not less than 90% of that of an adjacent sample of conductor not containing a joint.

- (d) Each conductor shall be uniformly insulated with solid polyethylene compound complying with British Standard BS 7878 Part 3 Grade L/MD. Reclaimed material shall not be used.

The construction of the insulated copper conductor shall be in accordance with Tables 4a and 4b.

Table 4a: Construction of Copper Conductor

CONDUCTOR	Material	Annealed copper wire
	Diameter	Nominal 0.6mm
INSULATION	Material	Polyethylene
	Thickness	Nominal 0.34
CONSTRUCTION	N/A	Pair

Table 4b: Colour Coding of Copper Conductor

PAIR No.	Colour coding
1	White - Orange
2	Red - Slate
3	Green - Black

6. ELECTRICAL CHARACTERISTICS OF CONDUCTORS

6.1 Conductor Resistance

- (a) All measured values of resistance shall be corrected to 20°C by the appropriate factor given in British Standard BS 6360.
- (b) Average conductor resistance shall not exceed 63 Ω /km at 20°C.
- (c) No conductors shall have value of resistance in excess of 67 Ω /km.

6.2 Mutual Capacitance

- (a) Mutual capacitance measurements shall be made at a suitable audio frequency. During measurements the aluminium foil and all conductors other than those under test shall be connected to earth.
- (b) The maximum average of mutual capacitance of the pairs shall not exceed 60 nF/km.
- (c) No pairs shall have values which exceed 64 nF/km.

6.3 Capacitance Unbalance

- (a) Pair-to-pair capacitance unbalance measurements shall be made at a suitable audio frequency. During the measurements the aluminium foil and all conductors other than those under test shall be connected to earth.
- (b) The measurements shall be corrected as follows, L being the length in metres of the cable under test, Lengths less than 100 metres being considered as 100 meters.
- (c) The measured values shall be divided by.

$$1/2 \times (L/2000 + \sqrt{L/2000})$$

- (d) Not more than 1% of the corrected capacitance unbalance measurements shall exceed 850 pF per 2000 meters, except that when the pair consists of two wires laid side-by-side, the values shall be recorded.

6.4 Insulation Resistance

After steady electrification with not less than 500V DC for one minute, the insulation resistance of each conductor in the cable measured with all other conductors and the screen connected together shall be not less than 6,500 Ω for a length of 1000 metres.

The electrical characteristics of the copper conductor shall be in accordance with Table 5.

Table 5: Electrical Characteristics

Item	Property
Conductor resistance @ 20°C	Maximum 67 Ω /km Minimum 63 Ω /km
Insulation resistance	Not less than 6,500 Ω /km
Dielectric strength	500 V DC for 1 min
Mutual capacitance (1kHz)	Maximum 64 nF/km Average 60 nF/km
Capacitance unbalance at 1kHz (Pair-to-pair)	850 pF/2000

7. OPTICAL PERFORMANCE OF CABLE

7.1 Attenuation

The cabled fibre shall be in accordance with attenuation coefficient values defined in specification BTC/1010/FIBRE.

7.2 Polarisation Mode Dispersion

The maximum value of PMD of the fibres in the cable shall be ≤ 0.3 ps/(km)^{0.5}. If statistical methods are used to obtain the PMD value, the supplier shall detail

information relating to the mean value of the PMD together with the confidence level with which the maximum value is achieved. Agreement of the PMD value shall be reached with Batelco Engineering prior to product supply.

The cable shall be measured in accordance with IEC 60794-3 (86A/434/RVN). Details of the test configuration, number of unit sections and measurement method chosen shall be presented and agreed with Batelco Engineering.

8. MECHANICAL AND ENVIRONMENTAL PERFORMANCE

The requirements of BTC/1015/FIBRE shall be met.

8.1 Mechanical Parameters

8.1.1 Crush Performance

Test Requirements

Cable length	≥ 30 metres
Maximum load applied	≈ 2000 Newton's
Duration of maximum load	$= 10$ minutes
Selection of fibres to be monitored	≥ 1 fibre/layer

Acceptance criteria

During test, no change in attenuation

After test, no change in attenuation

No significant damage to cable components.

8.1.2 Moving Bend Performance

Length of cable to be tested	≥ 50 metres
Diameter of mandrels	$= 12 \times$ cable diameter
Spacing of mandrels	$= 14 \times$ cable diameter

Draw speed of cable through the bend test rig.	≥ 5 metres/minute
Draw tension of cable	≥ 800 Newton's
Selection of fibres to be monitored	= all fibres in cable
Angle of orientation	= $0^{\circ}, 90^{\circ}$
Number of cycles	= 1 cycle/orientation
Acceptance criteria	
During test, no change in attenuation	
After test, no change in attenuation	
No significant damage to cable components.	

8.1.3 Cable Bend Performance

Test Requirements

Mandrel parameter	= 12 x cable diameter
Cable sample length	≥ 30 metres
Selection of fibres to be monitored	≥ 1 fibre/layer
Number of turns per cycle	= 3
Number of cycles	= 5

Acceptance criteria

During test, no change in attenuation

After test, no change in attenuation

No significant damage to cable components.

8.1.4 Torsion Performance

The cable shall be tested in accordance with IEC 60794-1-E7

Cable length under test (gauge length)	= 1 metre
Optical path length	> 30 metres
Load	> 100 Newton's
Selection of fibres to be monitored	= all fibres in cable
Number of turns	= + 1
Number of cycles	= 5
Acceptance criteria	
During test, no change in attenuation	
After test, no change in attenuation	
No significant damage to cable components.	

8.2 Environmental Parameters

8.2.1 Temperature Cycling of Optical Cables

Test requirements

Cable length under test (gauge length)	≥ 1000 metres
Temperature T1	= +20°C
Temperature T2	= -20°C
Temperature T3	= +60°C
Dwell times t1 & t4	≥ 4 hours
Dwell times t2 & t3	≥ 3 hours

Ramp rate of temperature	$\geq 1^{\circ}\text{C}/3$
Number of cycles	$= 3$
Selection of fibres	≥ 1 fibre/layer
Wavelength for measurement	$= 1310\text{nm} \& 1550 \text{nm}$
Measurement sampling rate	$\geq 1/10$ minutes
Acceptance criteria	
During test, maximum increase in fibre attenuation	$\leq 0.07\text{dB}/\text{Km}$
During test, maximum variation of fibre attenuation	$\leq 0.15\text{dB}/\text{Km}$
After test no change in attenuation.	

9. PRESSURISATION

9.1 Cable Pressure

All cables should to be pressurized to 620 millibar (9lbs) using dry air. Measurements are to be taken two days after pressurization and before shipment. The supplier shall provide pressure readings prior to factory inspection and shipment.

9.2 Pneumatic Resistance

The pneumatic resistance shall be measured in accordance with the method detailed in specification BTC/1015/FIBRE.

Test requirements

Length of cable to be tested	≥ 1000 metres
Air Pressure	$= 620$ mbars
Air Supply	$=$ Dry Air

Acceptance criteria

The value of pneumatic resistance of the cable shall not exceed

2000mbars.minutes/litres.km.

10. CABLE DELIVERY

The cables shall be delivered in the standard lengths of Table 1 on exterior grade, resin-bonded plywood reels or lightweight drums; or on strong wooden drums, in accordance with Specification BTC/1962/DRUMS. If a cable length different to the standard length is required, this shall be stated on the order.

11. CABLE ENDS

The cable ends shall be sealed to prevent the ingress of moisture, the sealing shall comply with BTC/1961/SHEATH.

12. TEST AND QUALITY CHECKS AND CERTIFICATION

The supplier shall deliver, along with the material supplied or by fax (before dispatch of the goods) a test report for each batch of material. The test report shall be forwarded to:-

Manager Access Network Development

Bahrain Telecommunications company

P. O. Box 14

Manama

Bahrain

The test report shall give the following information:-

Suppliers Name

Product description

Production batch number

Production date

Batelco specification number

Purchase order number

Results of test performed by the supplier.

Attestation to conformity to the specification.

Bahrain Telecommunications Company reserves the right to request the test report before dispatch of material, as well as to request further test reports upon prior agreement with the supplier.

13. REFERENCES

International Standard	IEC 60794-1
International Standard	IEC 60794-3 (86A/434/RVN)
British Standard	BS 6234
British Standard	BS 7878
Batelco Specification	BTC/1010/FIBRE
Batelco Specification	BTC/1015/FIBRE
Batelco Specification	BTC/1961/SHEATH
Batelco Specification	BTC/1962/DRUMS

Note:

Reference in this specification to any document listed above means, in any tender or contract, the edition any amendments current at the date of such tender or contract.

If any document has been superseded by another document, then the edition of the superseding document current at that date shall apply.

End of Specification

Issued by:

JWM V 1.59.DOC

Manager Access Network Development

Bahrain Telecommunications Co.

P. O. Box 14

Manama

Bahrain

Tel : 00973 884244

Fax : 00973 612999

Email : xa@btc.com.bh

SPECIFICATION BTC/1011/FIBRE

14. (AMENDMENTS FROM ISSUE 2 TO ISSUE 3)

14.1.1 Front Page

Editorial.

Clauses: 1, 3, 4, 4.2, 4.3, 4.5, 4.6, 6.4, and 13 (was 12 in Issue 1):

Editorial.

Clause: 2

Editorial – Fibre requirements referenced to specification BTC/1010/Fibre

Table 3:

Editorial.

Clause 5:

Harmonisation with latest BS specification for communication cable insulation materials, deleted 5 (e) for non relevance.

14.1.2 Clause 7.1:

New clause added to provide greater clarification on the attenuation performance requirements for the completed cable.

Clause 7.2:

New clause added to align with direction that ITU are taking in the methodology for the specification of Optical Fibre Cables.

Clause 8.14 (was 7.1.4 in Issue 2):

Acceptance criteria included.

Harmonisation with latest International Test method for Cable Torsion.

Clause 8.2.1 (was 7.2.1. in Issue 2):

Alignment to operating temperature range in clause 4.11.

Clause 9.2. (was 8.2. in Issue 2):

Test method in specification BTC/1015/Fibre referenced.

Clause 14:

New clause detailing history of specification.

APPENDIX 12 – OPTICAL FIBRE ACCEPTANCE PROCEDURES

1. RESPONSIBILITY

The responsibility for acceptance testing of In-Span Interconnect cables lies with Batelco.

Preliminary tests should be carried out to evaluate that the individual party's splice losses and power measurements are taken to satisfy the stated acceptance criteria, the procedure documented below defines the method of achieving this.

2. TEST METHOD

All fibres in the cable under test should be 'back spliced' at the Licensed Operator's end; i.e. Fibre 1 to Fibre 2, Fibre 3 to Fibre 4, Fibre 5 to Fibre 6 etc.

Acceptance testing is then carried out from the Batelco Gateway Switch building by Batelco.

3. OTDR TESTING

Each fibre should be measured at both 1310nm and 1550nm in both directions, and the mathematical average of the measured splice losses should be recorded. (Care should be taken to assign the correct splice loss to the appropriate fibre when measuring around back spliced fibres.)

Fibre splices indicating non-compliance to specification should be re-made. This remedial action will require re-measurement of the splice.

During OTDR measurements the fibre under test should be assessed for any nonlinear events over its total length.

Evidence of individual splice losses should be retained by each party until the agreed completion of cable commissioning.

Records of the splice loss measured at the back splice position should be noted for further reference using the form shown at Annex 1 of this Appendix 12 (Optical Fibre Cable Test Records – OTDR Results).

3.1 Power Readings

Utilising a suitable light source and power meter, power meter readings should be obtained using a fibre cut back method at both 1310nm and 1550nm operational windows.

The attenuation measured in both directions on any fibre under test should not differ by more than 0.5dB.

Providing that splice losses are within specification and no non-linear events have been identified during OTDR measurement, the individual fibre attenuation can be assessed as follows:

- (a) Measured overall attenuation minus the recorded splice loss measured at the back splice position divided by two (2).
- (b) The attenuation is calculated for both directions of transmission and at both 1310nm and 1550nm wavelengths.
- (c) Copy of all results should be recorded on forms in Annex 2 of this Appendix 12 (**Optical Fibre Cable Test Records - Power Meter Results**), retained and made available to both parties.

3.2 Measurement of Metallic Cable Elements

Annex 3 of this Appendix 12 (**Optical Fibre Cable Test Records – Metallic Results**) should be used to record the measured loop resistance and insulation resistance of the copper pairs (if applicable) within cables offered for In-Span Interconnect.

Annex 3 should also be used to record the end to end resistance of the moisture barrier and strength member.

Annex 1

OPTICAL FIBRE CABLE TEST RECORDS

OTDR RESULTS

Cable name: _____ **No :** _____

Fibre number: _____ **And** _____

Wavelength: 1310 / 1550 (delete as required)

Location of test: _____ **Date:** _____

Direction	Odd to Even Fibres (O to E)		Even to Odd Fibres (E to O)		(O to E) + (E to O) dB / 2	In limits? Yes/No
	Attenuation (dB)	Distance to splice	Attenuation (dB)	Distance to splice		
1						
2						
3						
4						
5						
6						
7						
8						
9						

10						
11						
12						
Back Splice						

Annex 2

OPTICAL FIBRE CABLE TEST RECORDS

POWER METER RESULTS

Cable name: _____ **No :** _____

Fibre number: _____ **And** _____

Wavelength: 1310 / 1550 (delete as required)

Location of test: _____ **Date:** _____

Optical attenuation acceptance limit _____ **dB per fibre**

Annex 3

OPTICAL FIBRE CABLE TEST RECORDS

METALLIC RESULTS

APPENDIX 13 – TESTING OF OPTICAL LINE SYSTEMS FOR IN-SPAN INTERCONNECT

Testing of Optical Line Systems Used for In-Span Interconnect

In order to test the optical line system between Batelco and the Licensed Operator, the following sequence of joint events should take place. Contact is to be established between the Batelco and the Licensed Operator personnel to perform the end to end tests as detailed below observing optical safety precautions.

- (a) All optical connectors cleaned at both ends of the link.
- (b) The transmit optical connector at the Licensed Operator site is to be connected to the line fibre when instructed to do so by the Batelco engineer.
- (c) The received optical power measured at the Batelco site and confirmed to be that expected bearing in mind the cable loss of the section.
- (d) The transmit optical connector at the Batelco site is to be connected to the line fibre when instructed to do so by the Licensed Operator engineer.
- (e) The received optical power measured at the Licensed Operator site and confirmed to be that expected bearing in mind the cable loss of the section.
- (f) A 2.048 Mbit/s output looped to the input at the Licensed Operator site, a pattern generator set to PRBS using a PRBS of $2^{23}-1$ and error detector with the received error-free signal connected to the 2.048 Mbit/s port at the Batelco site.
- (g) The optical connectors at each end of the link gently disturbed with no errors generated.
- (h) A pattern independence test carried out with no errors. The 4 patterns to be used for 2 minutes each are:
 - (i) All 0s
 - (ii) 01010.....
 - (iii) 0000000100000001.....
 - (iv) All 1s.

- (i) A distant alarm test in each direction, i.e. an alarm raised at the Licensed Operator site causes a distant alarm to be raised at the Batelco site and vice versa.
- (j) An error-free stability run for the required length of time, as detailed in the relevant equipment commissioning specification.

End to End Commissioning Tests for STM 1 SDH Optical Line Systems Used for In-Span Interconnect

In order to fully test the STM 1 link between Licensed Operator and Batelco, the following sequence of events will take place:

1. At the Batelco site, Batelco will perform the Batelco STM-1 tests set out in Annex 1 of this Appendix 13 (Batelco SDH STM-1 Test Sheet).
2. Stability Test - an error-free stability run for forty-eight (48) hours after the completion of the Batelco STM-1 tests.

Once all tests have been completed and passed, Batelco and the Licensed Operator will sign the form shown in Annex 2 of this Appendix 13 (Digital Line System Tested Satisfactorily - Confirmation Note).

Annex 1

BATELCO SDH STM-1 TEST SHEET**(Issue 1/NS7/2003)**

No	TEST NAME AND TEST EQUIPMENT TYPE	REF.	PASS FAIL	COMMENTS	DONE BY
1	OPTICAL OUTPUT POWER (Optical power meter type W&G)	G.707 G.958 for 1330nm			
2	OPTICAL RECEIVE SENSITIVITY (Optical power meter, optical attenuator and HP Omni BER 718 tester.)	G.707 G.958 for 1330nm			
3	OVERHEAD BYTE COMPARISON (HP Omni BER 718 tester)	STM-1 frame structure			
4	CONNECTIVITY AND LEVEL OF CONNECTION (Marconi NMS)	Marconi MV36/MV38			
5	MSP 1+1 PROTECTION (HP Omni BER 718 tester)	K1,K2 bytes+ physical connection			
6	ALARM MANAGEMENT (visual and NMS)+ (HP Omni BER 718 tester)	LOS, AIS, LOF, BERT			
7	SYNCHRONIZATION (HP Omni BER 718 tester)	S1, S2 bytes			
8	STM-1 SETTING (For Batelco equipment) Marconi Local controller	Table 1			

Table 1

SDH STM-1 CONFIGURATION SETTINGS			
Feature	Setting	Feature	Setting
AIS on RS-TIM	Enabled	AIS on HO-TIM	Enabled
RDI on RS-TIM	Enabled	RDI on HO-TIM	Enabled
AIS on MS-EXC	Enabled	AIS on PLM	Enabled

RDI on MS-EXC	Enabled	RDI on PLM	Enabled
AIS on VC Un equip	Enabled	AIS on HO-EXC	Enabled
RDI on VC Un equip	Enabled	RDI on HO-EXC	Enabled
Sect Trace Transmission	Disabled	MS DEG Threshold	10E - 6
Sect Trace Mism Detection	Disabled	HO PATH DEG Threshold	10E - 6
Path Trace (J1) Transmission	Disabled	Signal Label Expected	non spec



Path Trace (J1) Mism Transmission	Disabled	Signal Label Configured	non spec

GENERAL COMMENTS:

.....
.....
.....

Batelco Network Manager Signature:.....

Date:.....Code:.....

Ref: stm1_intrwork-issue_1

Annex 2

Optical Line System Tested Satisfactorily - Confirmation Note

We confirm that the optical line system between _____ and _____ has been tested and meets the specified requirements.

Agreed on behalf of
Batelco

Agreed on behalf
of

Signed _____

Signed _____

Name _____

Name _____

Date _____

Date _____

APPENDIX 14 – JOINT PROCEDURES FOR END TO END MULTIPLEX TRIBUTARY TESTING

1. TRIBUTARY END TO END TESTING DIGITAL BLOCKS

1.1 Introduction

This appendix details the procedures for configuring and lining-up In-Span Interconnect tributaries and higher order digital blocks. 2Mbit/s and STM-1 systems are covered.

1.2 Electrostatic Precautions

Electrostatic precautions must be observed.

1.3 Authority

The provision, rearrangement or cessation of higher order digital blocks are authorised by the issue of an order form.

1.4 Testing a Digital Block

All testing should be performed from the tributary interface at the Digital Distribution Frame (DDF). Where direct cabling is used, tests will need to be concluded from the Add Drop Multiplexer rack.

1.5 Tester Configuration

Set the bit by bit error tester to the tributary bit rate set out below:

Tributary Bit Rate (kbit/s)	Pseudo-Random Bit Pattern	Coded Output Signal
2048	$2^{23}-1$	HDB3

Stage 1: Tributary Identification with One Tester

- (a) At the control (Batelco end) station, connect a bit by bit tester (set at the tributary rate detailed in Tester Configuration) to tributary 1.
- (b) At the distant (Licensed Operator end) station loop tributary 1 in to out.
- (c) Reset tester error display and confirm synchronisation with NO ERRORS. (Note: Manually extinguish "SYNC-LOST" LED.)
- (d) To confirm you are testing the correct tributary, disconnect the loop on tributary 1.
- (e) Alarm Indication Signal (AIS) will be displayed together with 'SYNC-LOST'.
- (f) Repeat the above procedure for all tributaries on the Add Drop Multiplexer under test.

NB: The above can be performed unidirectionally using two bit by bit testers. This has the advantage of detecting any reversals on the DDF before Stage 2.

Stage 2: System Stability Test

- (a) Ensure all distant end tributaries are looped upon themselves, i.e. tributary 1 in to out, tributary 2 in to out.

Note: long term loops must be labelled indicating date loop applied, date of restoration due and contact details of test duty.

- (b) At the control (Batelco end) with the bit by bit tester set from Stage 1, connect the input of the tester to the output of tributary 1. Loop the input of tributary 1 to the output of tributary 2. Replicate for tributary 2 to 3 and 3 to 4. The last tributary input is connected to the tester output.
- (c) Reset tester error display and confirm synchronisation with NO ERRORS. (Note: Manually extinguish 'SYNC-LOST' LED).
- (d) To confirm tributary paths through the block, inject errors. On receipt of errors, reset as in (c) above.

- (e) Error count should continue for a duration of 30 minutes from commencement of the test with NO ERRORS. Set printer on tester so that error performance measurement can be left. Any accidental adjustment to the tester will be recorded.

Any errors should be regarded as a fault and investigated on a link by link basis. See paragraph 2 of this Appendix 14 (Error Performance).

- (f) Remove all loops from both stations.

1.6 Alarms

After digital line-up has been completed, but before traffic is routed through Add Drop Multiplexer, configure alarms for:

Power	prompt
Tributary I/P	prompt
Mux I/P	prompt
Frame Align	prompt
AIS	In-station
Dist Alarm	In-station
Clear	In-station

1.7 Test Results

Test results must be recorded by both Batelco and Licensed Operator as an aid to future fault location.

1.8 Switch To Switch Testing

Further functional tests should be carried out as set out in the Appendix 30 to this Joint Working Manual (Testing Procedures).

2. ERROR PERFORMANCE

2.1 Introduction

This paragraph details error performance limits for 2 Mbit/s systems.

2.2 Objective

To provide a zero error count.

Provision parameters for error performance should ensure that they meet the tightest parameters of any service the Batelco Network and the Licensed Operator Network carry.

2.3 Network Circuit Provision Procedure

The tests detailed below are using a bit by bit tester set at the tributary or 2 Mbit/s level with a Pseudo Random Binary Sequence (**PRBS**) pattern.

- (a) Make a unidirectional test (see Note 1 below) with a PRBS tester at each end of a system for 30 minutes.
- (b) Repeat test for the opposite direction.
- (c) If no errors are recorded the system may be put into service.
- (d) If any errors are recorded the system is regarded as faulty and should be monitored for a longer period.

Notes:

1. Unidirectional tests are specified to overcome faults which may be masked if the system is not immediately connected to terminal equipment on completion of these tests. If the same testing duty is responsible for subsequent multiplex connection or overall testing of a digital-digital exchange system then loop-back single ended testing may be employed.
2. In practice, much longer testing periods sometimes occur. In these cases an expansion of the Bit Error Rate (BER) in Note 3 should be adopted.

3. A BER of better than 25 errors in 30 minutes, 200 errors in 4 hours or 1200 errors in 24 hours is considered to be acceptable.

APPENDIX 15 – SAFE WORKING PROCEDURES FOR OPTICAL FIBRE CABLES

All Interconnect links should NOT be operated on “LIVE” but should be assumed to be HAZARDOUS.

APPENDIX 16 – SWITCH INFORMATION

OPERATOR _____

SWITCH SUPPLIER _____

SWITCH TYPE _____

SWITCH NAME _____

SWITCH ADDRESS _____

HARDWARE BUILD LEVEL _____

SOFTWARE BUILD LEVEL _____

SS7	Specification	Conformance	YES / NO
	Statement Available		

Interconnect Services

ISUP Version ((for example ETSI V2 orITU-T 92)

ETSI-ISUP	YES / NO
------------------	-----------------

En-bloc signalling	YES / NO
---------------------------	-----------------

Over-lap signalling	YES / NO
----------------------------	-----------------

Bothway circuits with unidirectional call direction	YES / NO
------------------------------------------------------------	-----------------

Bothway circuits with bothway call direction	YES / NO
-----------------------------------------------------	-----------------

Unidirectional circuits	YES / NO
--------------------------------	-----------------

Calling Line Identity Supplementary Services

Calling Line Identity Presentation **YES / NO**

Switch Information - Explanatory Notes

The form should be used by the Licensed Operator to provide the initial top level information about the proposed switch system build so that a comparison to the builds understood by Batelco can be made. This information will help determine the broad level of testing required and also indicate those areas where more detailed testing issues need to be discussed.

Notes on the information that needs to be provided.

The following top level information is used to identify the particular switch build: switch supplier, switch type or product and Build Level, with specific hardware and software identities. Both the switch and SS7 interface will need to be identified if they are different elements.

SS7 Specification Conformance Statement

The Licensed Operator will need to provide a conformance statement against the generic SS7 signalling specifications. This information will be needed to aid the agreements between the parties, which define the interface between the two Networks and also ensure adequate testing of features and services can be done.

APPENDIX 17 – INTERCONNECT CHANGE ADVICE FORMS

Form 17A

REQUESTOR REF:	ISSUE No:	REGISTRATION No:
OPERATOR NETWORK:		

SECTION 1 – BUILD IDENTIFICATION	
SYSTEM TYPE	
LOCATION	
EXISTING BUILD	
PROPOSED BUILD	
UNIT STATUS	IN SERVICE\PRE-NIT\SA TESTING

SECTION 2 – CHANGE IDENTIFICATION	
CHANGE TO SS7 INTERFACE	YES / NO
CHANGE TO SDH INTERFACE	YES / NO

SECTION 3 – CHANGE DESCRIPTION	
CHANGE TO HARDWARE	YES / NO
CHANGE TO SOFTWARE	YES / NO
DATA CHANGE	YES / NO
RECOMPILE OF SOFTWARE	YES / NO
CHANGES TO PROTOCOL	YES / NO
CHANGES TO MESSAGE FORMATS AND CONTENTS	YES / NO
ANY OTHER CHANGES THAT COULD AFFECT THE INTEREACE	YES / NO

SECTION 4 – TESTING	
TESTING ACTIVITIES	
TESTING INFORMATION	

SECTION 5–REQUESTOR
IDENTIFICATION

Requestor: [Batelco/ Licensed Operator]

Requestor Signature:

Date:

Requestor Contact Name [Print]:

Phone:

e-mail address:

Fax No:

SECTION 1 – CHANGE REGISTRATION

REGISTRATION No:

ISSUE No:

Interface Change

YES / NO

Change Status:

INFORM Requestor

SECTION 2: FACTORS AFFECTING TIME SCALES FOR IMPLEMENTATION:

SECTION 3: DETAILS OF CHANGE TO THE INTERFACE:

SECTION 4: ACTUAL/POTENTIAL EFFECTS ON INTERWORKING:

SECTION 5: ACTIONS REQUIRED:

SECTION 6 – CHANGE ACCEPTANCE BY RECIPIENT OF REQUEST

Accepted by: [insert name of recipient of change request ie. Batelco or Licensed Operator]

Contact Signature:

Date:

Contact Name [Print]:

Phone:

e-mail address:

Fax No:

APPENDIX 17 - CHANGE ADVICE FORM NOTES

The information detailed on the change advice forms is needed so that an assessment of the changes can be made and the correct level of testing can be agreed. This process ensures that testing can be kept to the minimum necessary to test the areas that may impact on the Network interface.

The requestor originating the change is required to complete both forms 17A and 17B. The forms should be sent to the appropriate contact representing the other party.

FORM - 17A

Section 1: Build Identification

This section is used to provide the key details of the build.

System Type:	Details of the System type affected by the change.
Location:	The switches affected by this change.
Existing Build:	The specific hardware and software identities. This is the tested build that is currently in service and which will be compared to the proposed build so that any differences can be assessed.
Proposed Build:	The specific hardware and software identities after the change.
Unit Status:	The status of the switches affected by the change.

Section 2: Change Identification

This section is used to identify whether the change is to the SS7 or the SDH interface.

Section 3: Change Description

This section gives the specific detail related to the areas of the Network interface that have changed. Any additional information, which will aid the understanding of the implications of the change, should be sent with the completed form.

Section 4: Testing

This section is used to provide details of any existing testing information. For example, the supplier may have performed some simulator tests and the results could be used by Batelco to remove the need for further testing or to allow tests to the Batelco Network to take place. Any relevant testing information that is available should be supplied so that testing effort is not duplicated.

Section 5: Requestor Identification

The requestor should nominate an appropriate contact. FORM - 17B

Section 1: Change Registration

This section is used to summarise details of the change. A registration number and issue number are allocated.

Section 2: Factors affecting timescales for Implementation

This section is used by the originator of the change to list any factors, which may affect the timescales for the implementation of the change.

Section 3: Details of change to the interface

This section is used by the originator of the change to provide details of changes to the network interface.

Section 4: Actual/Potential effects on interworking

This section is used by the originator to list the effects of the change on interworking.

Section 5: Actions required

This section is used by the originator of the change to list the actions required of the other party.

Section 6: Change Acceptance

The party receiving the change advice should sign and return the form once it has agreed the change and a test schedule (if required).

APPENDIX 18 – AUTHORISATION CERTIFICATE FOR FIRST LIVE TRAFFIC TESTING

JOINT AUTHORISATION FOR THE CONNECTION OF BATELCO AND LICENSED OPERATOR SWITCHES FOR FIRST LIVE TRAFFIC TESTING USING SS7 SIGNALLING.

This certificate gives authorisation for the connection of the switch builds shown for the First Live Traffic Testing phase only and is subject to the conditions shown below.

General compliance with the generic interface specifications are confirmed, the major agreed exceptions and conditions are shown on the attached build register. Full details are documented in the SS7 interface conformance documents for the builds shown.

Conditions

Confirm that the switch systems are ready for service use and have suitable in service data applied.

Ensure the Build Levels shown have the relevant data and software corrections, which were agreed as a result of any previous testing.

Ensure an accounting system is in use which can accurately produce interconnect accounting information.

Required Information	Batelco	Licensed Operator
Switch Type		
Switch Build		
Interconnecting Sites		

Agreed on behalf of
Batelco

Agreed on behalf of

Signed	_____	Signed	_____
Name	_____	Name	_____
Date	_____	Date	_____

APPENDIX 19 – INTERCONNECT TRAFFIC REQUIREMENTS: SUMMARY

Traffic Class	Busy Hour	Y -	Y -	Y -	Y -	Y -	Y -	Y -	Y -	Year
		—	—	—	—	—	—	—	—	Ending
		Q	Q	Q	Q	Q	Q	Q	Q	—
		—	—	—	—	—	—	—	—	
GSM Terminating	Day									
	Evening									
PSTN Terminating	Day									
	Evening									
Paging Terminating	Day									
	Evening									
Freephone Origination										
Premium Rate Origination										
Directory Assistance										
Emergency Calls										
Speaking Clock										
Wholesale IDD										
Inbound Operator										

Outbound Operator										
National Collect SMS Terminating										

Note: Requirement to be stated in Erlang and Call Attempts

Submitted on behalf of [insert name of Access Seeker]

Agreed on behalf of [insert name of Access Provider]

Signed

Signed

Name

Name

Date

Date

Issue number:

APPENDIX 19 - EXPLANATORY NOTES

This form details the Forecasts for the various traffic types on a route between a Licensed Operator Switch Connection and a Batelco Gateway Switch.

Traffic Information

Insert the years and quarters applicable to the forecast into the traffic forecast header in the spaces provided, commencing with the quarter in which the current Capacity Profile commences.

For each quarter for the first 24 months provide day and evening busy hour Erlang and all attempt figures for each applicable traffic type. After the route has been in service for 24 months a bulk figure for the third forecast year should be provided.

Signature

The form should be signed by the Access Seeker when it is sent to the Access Provider and by the Access Provider when the Forecast has been agreed.

APPENDIX 20 – 12 MONTH 2MBIT/S SWITCH PORT CAPACITY - ORDERING PROFILE

Licensed Operator	Batelco	Path	Existing	Traffic	Signalling	z	*	*	*	*	*	*	*	*	*	*		
Switch	Switch	A or B	Network	Type	Link		1	2	3	4	5	6	7	8	9	10	11	12
			#			P/R	+	+	+	+	+	+	+	+	+	+	+	+
						P/R												
						P/R												

Advance Capacity Order

* Insert month abbreviations # Insert relevant reference number

z Identify profile type (P - Provision / R - Re-arrangement) - delete inapplicable type

+ Insert quantity to be ordered in the months shown

Submitted on behalf of
[insert name of Licensed
Operator] _____

Agreed on behalf of Batelco

Signed _____

Signed _____

Name _____

Name _____

Date _____

Date _____

Issue number: _____

[NB – Empty tables deleted from this page.]

APPENDIX 20 - EXPLANATORY NOTES

This form records the proposed ordering profile between the Licensed Operator and Batelco for existing and proposed Interconnect Links.

Profile

The header should be completed showing month abbreviations with the month shown in the main header. For each required route between a Licensed Operator Switch Connection and a Batelco Switch Connection, the switch names should be inserted. The number of existing Circuits on the route should be entered. A new row should be used for each profile type (entering the type P or R in the column as indicated). In the month boxes the quantities of 2 Mbit/s Circuits that the Licensed Operator intends to order in that month should be inserted.

Note: the first 4 months shown are an Advance Capacity Order, the next 8 months are indicative only.

Signature

The forms should be signed by the Access Seeker on submission. The Access Provider will sign to indicate agreement.

APPENDIX 21 – INTERCONNECT ORDER ACKNOWLEDGMENT

To [insert name of Access Seeker]

Attention

Fax Date _____

From [insert name of Access Provider]

Phone

Fax

Dear Customer,

We are pleased to accept your Provision/Rearrangement/Cessation/Cancellation* Interconnect order as follows:

***delete as appropriate**

Link Number

Purchase Order Number

Licensed Operator Switch

Batelco Switch

Circuit Number

RFT Date

Regards,

APPENDIX 22 – INTERCONNECT ORDER COMPLETION

To [insert name of Access Seeker]

Attention

Fax Date _____

From [insert name of Access Provider]

Phone

Fax

Dear Customer,

Your Provision/Rearrangement/Cessation/Cancellation* Interconnect No _____

Dated ___ / ___ / ___ was completed as follows:-

*delete as appropriate

Link Number

Capacity Order Number

Licensed Operator Switch

Batelco Switch

Circuit Number

RFS Date

Regards,

APPENDIX 23 – ROUTE ADVICE FORMS

IN CONFIDENCE

Batelco / Licensed Operator ROUTE ADVICE (SRA)

Licensed Operator name	
-------------------------------	--

Licensed Operator Switch	
---------------------------------	--

Batelco Switch	
-----------------------	--

SRA Serial Number		Issue		Page		Of	
-------------------	--	-------	--	------	--	----	--

Route Designation		-	
-------------------	--	---	--

Circuit Information

	Service Order	Circuit Designations	Timeslots	CIC	Term. Batelco	Device MTC
1						
Transmission path						
2						
Transmission path						
3						
Transmission path						
4						
Transmission path						
5						
Transmission path						
6						
Transmission path						
7						
Transmission path						
8						
Transmission path						
9						
Transmission path						

10						
Transmission path						

Directionality of Circuits

Both ways / Incoming Batelco / Outgoing Batelco

C7 Point Code and Protocol

Signaling Point Codes to be used for this Interconnect:

Format	Batelco		Licensed Operator	
	National	International	National	International
ITU	<input type="text"/>	<input type="text"/>	<input type="text"/>	<input type="text"/>
Hex.	<input type="text"/>	<input type="text"/>	<input type="text"/>	<input type="text"/>
Decimal	<input type="text"/>	<input type="text"/>	<input type="text"/>	<input type="text"/>

	Batelco	Licensed Operator
Network Indicator	<input type="text"/>	<input type="text"/>
C7 Protocol	<input type="text"/>	<input type="text"/>
Protocol Version	<input type="text"/>	<input type="text"/>

Routing Information

Method Of Circuit Selection	Control On Dual Seizure	Reset Facilities
<input type="text"/>	<input type="text"/>	<input type="text"/>
Signaling Mode	Continuity Check	Load Sharing
<input type="text"/>	<input type="text"/>	<input type="text"/>

C7 Signaling Link Set Information

	Signaling Link Designation	SLC Code
Link 1	<input type="text"/>	<input type="text"/>
Link 2	<input type="text"/>	<input type="text"/>

C7 Network Diagram

Signalling Routing

Signalling Relation	Route	Primary Route	Secondary Route
<input type="text"/>	<input type="text"/>	<input type="text"/>	<input type="text"/>
<input type="text"/>	<input type="text"/>	<input type="text"/>	<input type="text"/>

APPENDIX 23 – EXPLANATORY NOTES

IN CONFIDENCE

Batelco/Licensed Operator ROUTE ADVICE (SRA)

SRA Serial Number		Issue:		Page:		of	
-------------------	--	--------	--	-------	--	----	--

Route Designation	Note 1	-	
-------------------	--------	---	--

Point of Connection:

TRAFFIC ROUTE TERMINALS		TERMINATION	POINT CODE
A End:	Note 2	Note 3	Note 4
B End:	Note 5	Note 6	Note 7
Work details:		Note 8	
Provision control		Maintenance control	Extended distribution
Signalling type: Note 9		Mode:	
STP routings			
Between			
A End and B End			

Remarks:	Note 10
----------	---------

Total copies:	Copies to:	Date of issue	
		Issued by:	
		Contact	Note 11
		Telephone	Note 11

IN CONFIDENCE

Batelco/Licensed Operator ROUTE ADVICE (SRA)

SRA Serial Number		Issue:		Page:		of	
-------------------	--	--------	--	-------	--	----	--

Route Designation	Note 1	-	
-------------------	--------	---	--

Exchange Links												
Interconnection	Tributary	Batelco RFT Date	2Mbit/s Term	Order Number	TS	NWB	TF C	1 st CIC	SS7 SLC	Sync	Status	Remarks
Note	Note	Note	Note	Note				Not	Not	Note	Note	Note

Note	Remarks
1.	A-End to B-End route code
	A-End Switch Name
	A-End Switch Type
	A End switch Own Point Code (NB could be more than one Point Code per switch)
	B-End Switch Name
	B-End Switch Type
	B-End switch Own Point Code (NB could be more than one Point Code per switch)
	Used for any Remarks as required or left blank
	SS7
	Licensed Operator Order number and reasons for issue of SRA for example, "Add 3 systems"
	The Name and telephone number of the SRA issuing officer
	Interconnect bearer number
	Tributary allocation
	Ready for Test date for each individual bearer (In the case of ceases the Cease Date)
	Batelco switch 2Mbit/s termination
	The Order Number against those bearers being provided (or ceased) on this issue of the SRA. Bearers provided on previous orders/issues will have the relevant order number

	shown against them.
	1st circuit identification code (CIC) in each Network Band for example, NWB 0 - 1st CIC = 1, NWB 1 - 1st CIC = 17, NWB 2 - 1 st CIC = 33, NWB 3 - 1 st CIC = 49 etc. The NWBs are to be separated into two groups: being the Capacity required by a party in respect of the traffic (ingress to its network and egress from its network) for which that party is responsible as the Access Seeker.
	0, 1, 2 or 3 for SS7 Signalling Links
	YES for Synchronisation Link or leave blank
	WOR (Working), ICP (In Course of Provision) or ICC (In Course of Cessation)
	Remarks as required
	route identity or leave blank
	Total Timeslots

APPENDIX 24 – RFT CERTIFICATE

Certificate Reference Number _____

TO:

FROM: BATELCO CARRIER SERVICES DIVISION

Batelco CSD certifies that as far as it is aware each party has completed all the activities agreed as required on the following Interconnect links necessary for testing.

Order Reference	Batelco Switch Connection	Licensed Operator Switch Connection	Circuits and Type

Signed _____

Name _____

Date _____

Reference: _____

APPENDIX 25 – SWITCH TO SWITCH INTERCONNECTION AUTHORISATION CERTIFICATE

JOINT AUTHORISATION FOR THE CONNECTION OF BATELCO AND LICENSED OPERATOR SWITCHES FOR OPERATIONAL USE USING SS7 SIGNALLING.

This certificate gives authorisation for the connection of the switch builds shown for the service operational use and is subject to the conditions shown below. General compliance with the generic interface specifications are confirmed, with the major agreed exceptions and conditions are shown on the attached build register. Full details are documented in the SS7 interface conformance documents for the builds shown.

Conditions

Confirm that the switch systems are ready for service use and have suitable in service data applied.

Ensure the Build Levels shown have the relevant data and software corrections, which were agreed as a result of any previous testing.

Ensure an accounting system is in use which can accurately produce interconnect accounting information.

Required Information	Batelco	Licensed Operator
Switch Type		
Switch Build		
Interconnecting Sites		

Agreed on behalf of
Batelco

Agreed on behalf of

Signed

Signed

Name _____ Name _____
Date _____ Date _____



APPENDIX 26 – CAPACITY ORDER FORM

Interconnect Capacity Order Submitted by: _____ Ref : _____

Licensed Operator Switch Name	
Batelco Point Code	
Licensed Operator Switch point code	
Batelco Switch Name	
Batelco Point Code	

	Equipment Quantities	Type of Order P- Provision C- Cessation	Customer required by date	Access Link identifier	Traffic Type	Schedules (Requirements)

		R-Rearrangement				
Intra-building Links						
General						

Agreed on behalf of
Batelco

Agreed on behalf of

Signed

Signed

Name

Name

Date

Date

APPENDIX 26 – EXPLANATORY NOTES

Interconnect Capacity Order Submitted by: _____ Ref : _____

Licensed Operator Switch Name	Switch names as agreed at Technical Review Meeting
Batelco Point Code	
Licensed Operator Switch point code	
Batelco Switch Name	Switch names as agreed at Technical Review Meeting

	Equipment Quantities	Type of Order P- Provision C- Cessation R-Rearrangement	Customer required by date Note 1	Access Link identifier Note 2	Traffic Type	Schedules (Requirements) Note 3
Intra-building Links	Enter number	Enter type	Completion date (CRD) requested by the Access Seeker. The Access	Identity of the STM-1 link on which the capacity is to be built	Type of traffic (egress, ingress etc) to be carried over this link	Details of the service type to be enabled over this capacity



			Provider will attempt to make the RFT date match the CRD where possible.	built		
General	Customer specific information					

Agreed on behalf of Batelco

Agreed on behalf of

Signed

Signed

Name

Name

Date

Date

Notes

- Note 1 CRD requested by the Access Seeker. The Access Provider will attempt to make the RFT match the CRD where possible.
- Note 2 Identification of the STM-1 link over which the Interconnection capacity is to be routed.
- Note 3 Wholesale services to be enabled over this capacity

APPENDIX 27 – TESTING ESCALATION PROCESS

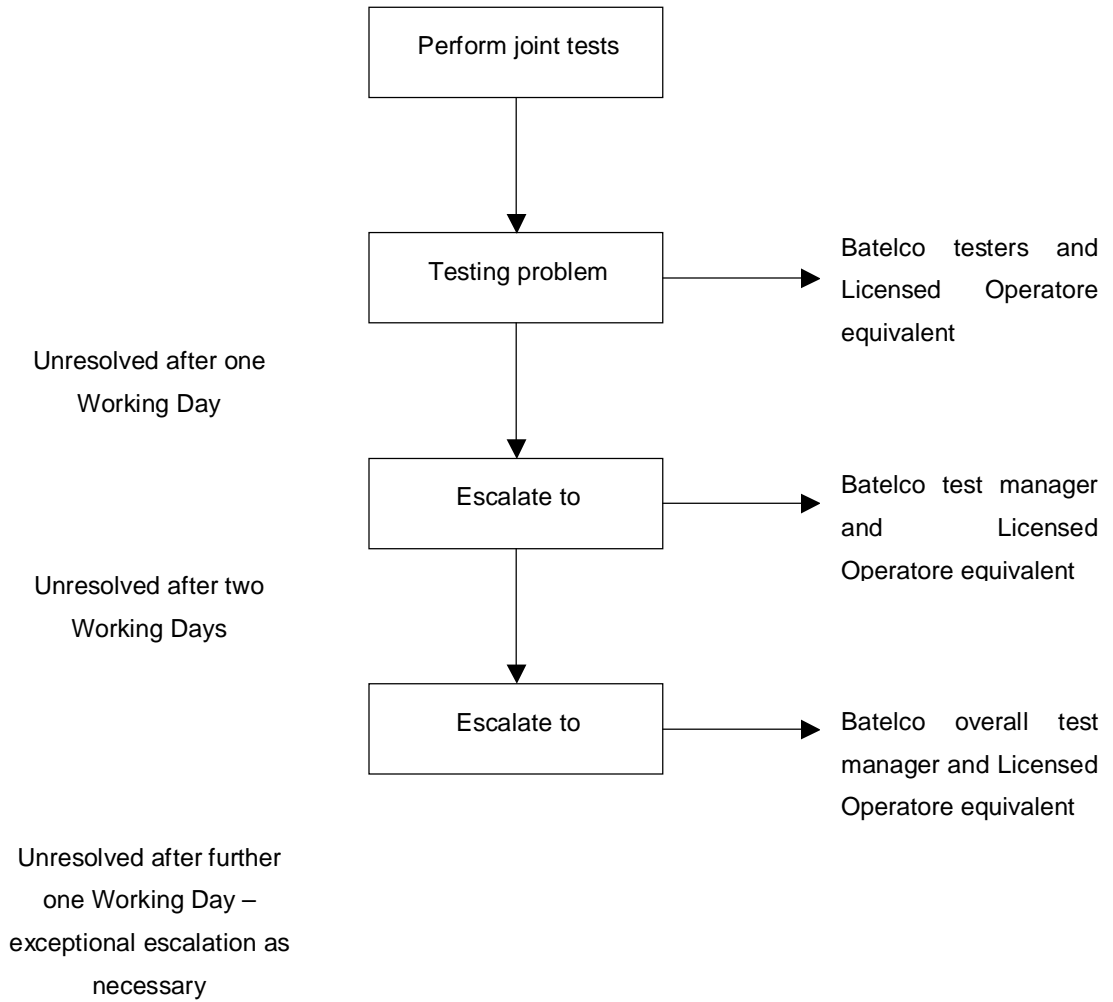

APPENDIX 28 – ROUTING PLANS

Licensed Operator _____ Reference _____

Service Type	Number Range	
PSTN Terminating		
GSM Terminating		
Paging Terminating		
Freephone Originating		
Premium Service Originating		
Emergency Calls		
National Collect		
Inbound Operator		
Outbound Operator		
Speaking Clock		

Routing to Licensed Operator Switch	Batelco Point Code	Batelco switch name	

**Agreed on behalf
of Batelco**

Agreed on behalf of

Signed

Signed

Name

Name

Date

Date

APPENDIX 28 – EXAMPLE – INGRESS TRAFFIC

Licensed Operator _____ Reference _____ Note 1

Service Type	Number Range	
PSTN Terminating		
GSM Terminating		
Paging Terminating		
Freephone Originating		
Premium Service Originating		
Emergency Calls		
National Collect		
Inbound Operator		
Outbound Operator		
Speaking Clock		

Routing to Licensed Operator Switch at	Batelco Point Code Note 2	Batelco switch name	

**Agreed on behalf
of Batelco**

Agreed on behalf of

Signed

Signed

Name

Name

Date

Date

COMPLETION GUIDANCE

The party responsible for each traffic type should produce a routing plan, which will be agreed by Batelco and the Licensed Operator. The Licensed Operator name should be completed. The number ranges for each of the services to be covered by the routing plan should be inserted.

NOTES

Note 1 The originator of the routing plan should add a reference number. To facilitate order validation the order will refer to an agreed routing plan by quoting the relevant reference number. The originator should update the reference number when the routing plan changes.

Note 2 The Point Code is the unique Batelco designation for a switch. This column will be completed by the Batelco person responsible for agreeing the routing plan.

APPENDIX 29 – NETWORK DESCRIPTION

[Batelco to insert]

APPENDIX 30 – TESTING PROCEDURES

TESTING

1. INTERCONNECTION TESTING - OBJECTIVES AND SCOPE

1.1 Objectives

This Appendix details the approach for testing the Interconnection between the Batelco Network and the Licensed Operator Network.

The objective of the testing are:

- to maintain the integrity of both Networks
- to meet the contractual specifications
- to locate and enable resolution of faults with the Interconnection
- to ensure that billing is completed correctly

1.2 Scope

This Appendix describes:

- process to support the testing
- project plan to support the testing
- roles and responsibilities
- phases of testing with entry and exit criteria
- detailed test cases
- results sheets
- how to manage a test failure

2. INTERCONNECT TESTING FRAMEWORK

The following framework is to be used to support Interconnect testing.

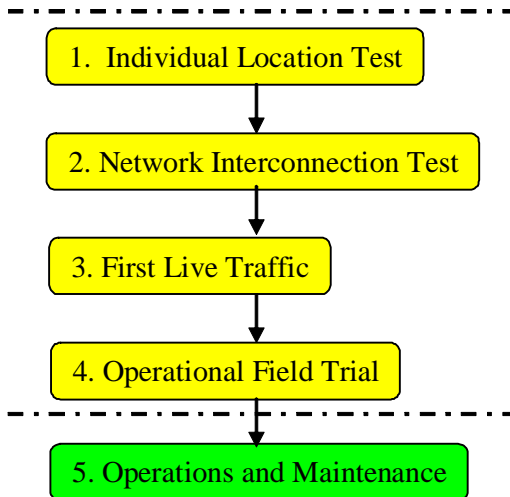

Fig. 1 - Process flow for Interconnection Testing.

The table sets out the phases of Interconnection testing

Individual Location Test	This phase of the testing verifies that the network of Batelco and the Licensed Operator are suitable for Interconnection. Each party must demonstrate that their interface conforms to the technical specifications in this Joint Working Manual.
Network Interworking Test	The NIT ensures the interoperability of the Networks, management of the Interconnect Link, tests whether all types of Telephone Call can be made and includes SS7 tests and exchange of CDR records.
First Live Traffic Testing	This is the first trial of the Interconnection in a test field environment with limited non-billable traffic. This phase considers maintenance and fault handling procedures, and verifies that the correct bills are delivered. It also tests that the roles and responsibilities are clear.
Operational Field Trial	This is the phase prior to the general operation of the Interconnection. During this phase, fine-tuning of operational procedures takes place. All functions must be verified including start-up/shut-down procedures,

	disaster recovery, security, and performance under severe load. This phase uses non-billable and billable traffic depending on the test.
--	------------------------------------------------------------------------------------------------------------------------------------------

3. TEST SPECIFICATION STRUCTURE

Each of the test phases will follow the same structure to derive and document the tests.

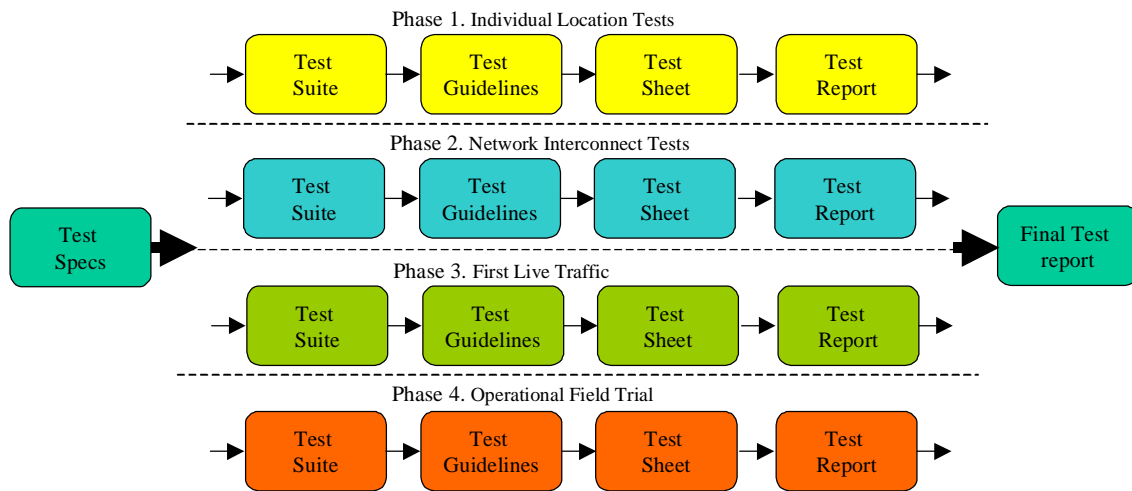

Fig. 2 - Structure of each test phase

Technical Master Plan

The Technical Master Plan contains the total set of test suites and test guidelines agreed between both parties to support the testing. This shall include, at a minimum, the tests set out in Annex 1 to this Appendix 30 (**Summary of Tests**).

Test Suite

The test suite is a set of defined test guidelines that relate to a particular functionality e.g. billing, interoperability. Each or part of a test suite can be tested against any of the four test phases.

Test Guidelines

The test guidelines contain:

- list of all the test cases to be completed
- justification for test cases
- detailed test case procedures
- test case pass/fail criteria
- details of other test data to be recorded
- planning to co-ordinate and track the testing progress

Test Sheet

The test sheet contains an accurate record of the test completed and the outcome of the test.

Test Report

The test report is a summary of the tests executed and provides details on faults, re-tests and exceptions. The test report is signed by both parties and is proof that the testing was completed. It is the main input to deciding whether the current phase of work can be exited.

The Final Test Report is compiled at the end of all the testing and highlights any outstanding faults, issues and concerns. It is the main input into deciding whether the joining service is ready to become fully operational.

4. TEST PHASES

4.1 Individual Location Test (ILT)

Process

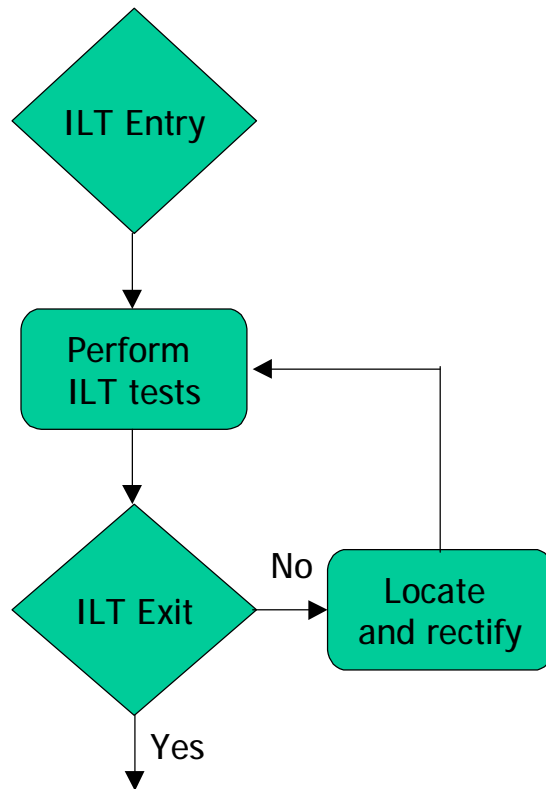

Fig. 3 - Process flow for Individual Location Test.

The goal of the ILT is to determine whether the infrastructure of each party exhibits sufficient functionality to interconnect. The tests consider the following areas:

- Conformance to relevant communication standards and technical specifications as set out in Appendices 1 through 4 of this Joint Working Manual (Technical Specifications to Specification of the Generic Signalling System for Interconnection)
- Statement about the implementation of the charging mechanisms
- Charging calibration

Each party performs its own ILT. If either party fails the testing the Interconnection cannot proceed until the fault(s) have been corrected. Each party is responsible for correcting any faults and carrying out any modifications or additions to its own interconnect equipment to rectify the situation.

Entry Criteria	Signed contract / agreement on the connection;
----------------	------------------------------------------------

	<p>test guidelines completed for this phase;</p> <p>Each party has sufficient resource available to complete this phase of testing;</p> <p>Provisional project plan drafted.</p>
Exit Criteria	<p>Each party has completed ILT and passed all tests;</p> <p>List of known deviations and imperfections available;</p> <p>No known fatal, inadmissible or major faults;</p> <p>Test results made available to each party;</p> <p>Test report is approved and signed by both parties.</p>

4.2 Network Interworking Test (NIT)

Process

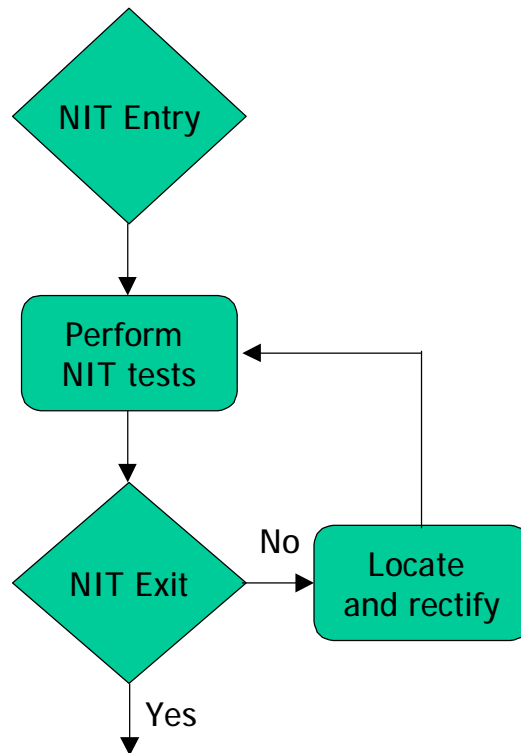

Fig. 4 - Process flow for Network Interworking Test.

This phase of testing minimises operational risk for both parties. The NIT consider the following areas:

- Interoperability of the signalling traffic
- Check whether charging mechanisms of both parties are in line

Entry Criteria	<p>Project plan, documented and signed by both parties;</p> <p>List of known deviations and imperfections available;</p> <p>Test guidelines have been completed for this phase;</p> <p>Both parties have sufficient resource available to complete this phase of testing;</p> <p>The Interconnect Link between Batelco and the Licensed Operator is ready for this phase of testing.</p>
----------------	------------------------------------------------------------------------------------------------------------------------------------------------------------------------------------------------------------------------------------------------------------------------------------------------------------------------------------------------------------------------------------------

Exit Criteria	Successful completion of the NIT; No known fatal, inadmissible or major faults; Planned solution for all faults has been documented; Test results made available to each party; Test report is approved and signed by both parties.
---------------	-----------------------------------------------------------------------------------------------------------------------------------------------------------------------------------------------------------------------------------------------------------------

4.3 First Live Traffic Testing (FLT)

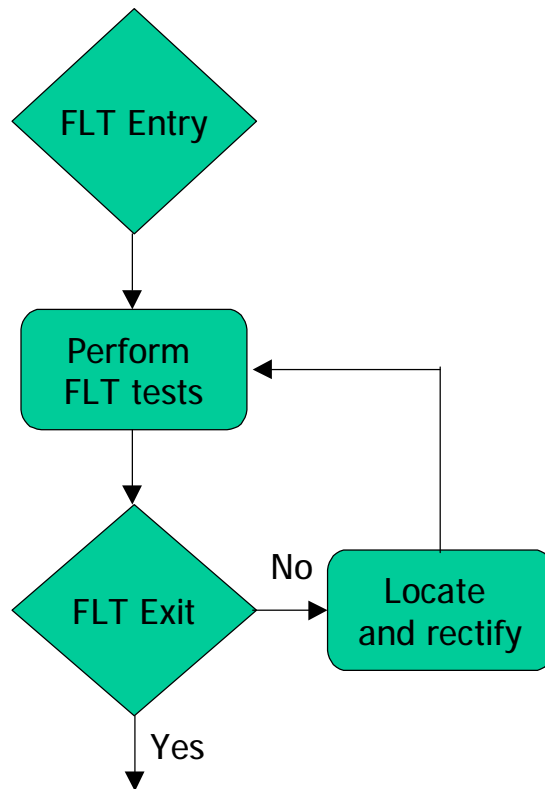

Fig. 5 - Process flow for First Live Traffic Testing

The First Live Traffic Testing determines whether the Network of both parties are correctly interconnected. Further, billing and supporting processes are tested during the First Live Traffic Testing.

No billable traffic should be used during this phase of the testing.

The First Live Traffic Testing consider the following areas:

- Interoperability of signalling traffic
- Service tests (can all types of calls be established)
- Routing tests (is the Licensed Operator reachable from all locations)
- Check whether charging mechanisms of both parties are in line
- Bill test (on basis of CDRs from test traffic)
- Process test (e.g. maintenance and error procedure)

Entry Criteria	<p>List of known deviations and imperfections available;</p> <p>Both parties have sufficient resource available to complete this phase of testing;</p> <p>The Interconnect Link between Batelco and the Licensed Operator is fully installed and operational;</p> <p>List of known deviations and imperfections available;</p> <p>Test guidelines have been completed for this phase;</p> <p>O and M procedures are available.</p>
----------------	------------------------------------------------------------------------------------------------------------------------------------------------------------------------------------------------------------------------------------------------------------------------------------------------------------------------------------------------------------------------------------------------------------------------------------

Exit Criteria	Successful completion of the First Live Traffic Testing; No fatal, inadmissible or major faults are present; Planned solution for all faults has been documented; Test results made available to each party; Test report is approved and signed by both parties.
---------------	----------------------------------------------------------------------------------------------------------------------------------------------------------------------------------------------------------------------------------------------------------------------------------------------

4.4 Operational Field Trial (OFT)

Process

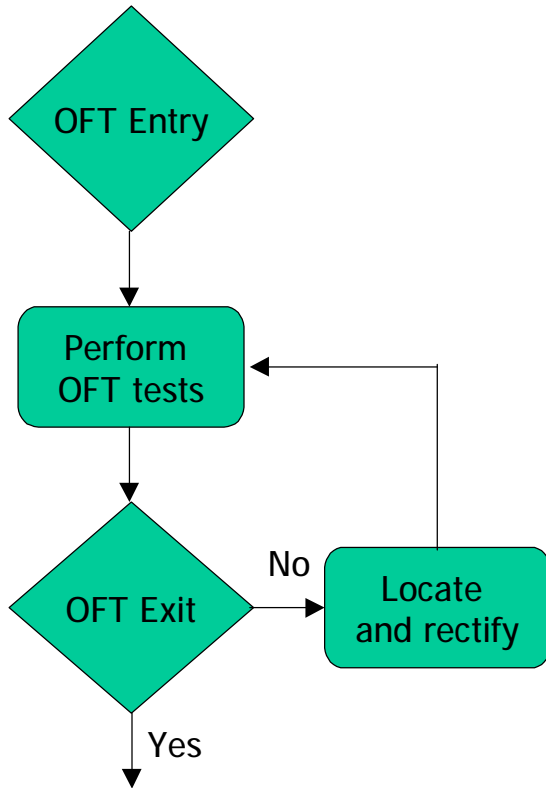

Fig. 5 - Process flow for Operational Field Trial

The Operational Field Trial is the phase prior to general availability of the Interconnection. During the Operational Field Trial all outstanding faults from previous test phases have to be resolved. During this phase billable traffic is passed and the volume of traffic means that faults are more likely to occur and this phase ensures that the operational and maintenance procedures are effective to deal with any issues that will arise.

Entry Criteria	No changes in the interconnection since conclusion of the previous phase of testing; List of known deviations and imperfections available; Test guidelines completed for this phase; Both parties have sufficient resource available to complete this phase of
----------------	-------------------------------------------------------------------------------------------------------------------------------------------------------------------------------------------------------------------------------------------------------------------------------------

	testing.
Exit Criteria	<p>No faults are present;</p> <p>Support for further field introduction is available;</p> <p>Performance and stability statistics are within the limits defined in the contractual agreement;</p> <p>Applicable O and M procedures approved;</p> <p>Test results made available to each party;</p> <p>Operational Field Trial Test Report is approved and signed by both parties;</p> <p>Final Test Report is approved and signed by both parties.</p>

5. TEST SHEETS AND REPORT

The test sheets contain the results of executed tests for each test phase. These results can be positive (passed), negative (failed) or impossible to execute (inconclusive); and where applicable additional information may need to be recorded.

For each phase of testing a test report must be completed. In all cases the test report should be completed and signed by both parties. The test report should at least reflect the tests that have been performed, whether the result was as expected or if deviations were observed.

6. TEST SUITES

The interconnect test suites required are shown below. Within each suite there are key areas of testing, which are shown below. Agreement to these need to be confirmed through the project plan and then further detailed in the test guidelines.

	Test Suites	Tests Phases			
		ILT	NIT	FLT	OFT
1	Conformance tests: 1. Protocol conformance 2. Electrical conformance 3. EMC conformance 4. Local Operation Tests	X X X X			
2	Interoperability tests: 1. End to end transmission 2. Network Synchronisation 3. SS7 signalling 4. Network routing 5. Network management		X X X X X	X X X X	X X X X
3	Stability and Security tests: 1. Load tests 2. Stress tests (fault situations) 3. Fraud	X 	X X X	X X	
4	Service tests: 1. Services from Batelco to Licensed Operator			X	X

	Licensed Operator			X	X
	2. Services from Licensed Operator to Batelco			X	X
	3. Changed services			X	X
	4. New services				
5	Billing:				X
	1. Charging calibration	X	X	X	X
	2. Charging per service (CDRs)		X	X	X
	3. Billing aggregates			X	X
	4. Billing service			X	X
6	Processes:				
	1. Service and Element management			X	X
	2. Operation processes			X	X
	3. Maintenance processes			X	X
	4. Customer processes			X	X

The test suites are described in overview below.

Conformance Testing

The test suite confirms that the protocol supported meets the technical specification. Conformance testing deals with the behaviour of the protocol, and not with processing capacity under critical load conditions. It may also address invalid behaviour testing.

Interoperability Testing

An interoperability test involves at least Networks that are interconnected. In these tests it is verified whether elements of a procedure (including parameters) across the common boundary, are in compliance with the relevant specification set out in this Joint Working Manual. The test sequences across the point of observation are not generated or inserted at the point of observation itself, but at interfaces contained within the Networks under test.

Stability and Security Test

Stability tests consist of load and stress tests. Load tests are tests of the Interconnection between the Batelco Switch Connection and the Licensed Operator Switch Connection in situations of relatively heavy use. Stress tests are tests in which fault situations are introduced in the Interconnection. The point of observation is the common boundary between the interconnected Networks. In both tests it should be verified that the Interconnection works under extreme circumstances. Network fraud testing is included in this test suite.

Service Test

These tests ensure the services from Batelco by the Licensed Operator and vice versa will operate in a manner that is compliant with the Service Description and technical characteristics.

Billing

Billing verifies the charging mechanism (based on CDR generation) supported by both parties is accurate and meets the agreed specification.

Processes

Process tests consist of testing: operation, maintenance and customer processes. It also includes the documentation, training of personnel and support of the interconnection. In some of these areas an actual test case cannot be written to test a process and the relevant people, as part of the exit criteria, can review the process.

7. FAULT HANDLING PROCEDURE TO BE USED IN TESTING PHASES

If a Fault is identified it should be registered, the test manager for the phase informed, classified, passed on to the installation / development team and resolved. When the Fault is resolved the new implementation may need to be tested again and the result recorded. When the retest is successful, the Fault can be closed on the Fault list that the test manager controls.

The test teams of either party can detect Faults. The test manager for the corresponding test phase issues a Fault report (see Annex 2 of this Appendix 30 (**Fault Report Template for Testing**)) and registers it on the Fault list (see Annex 3 of this Appendix 30 (**Fault List**)). The Fault report includes Fault classification. The classification is defined by mutual agreement between the test managers. If there is a conflict about the classification, the overall test managers can be consulted.

The Fault report and Fault list use the same numbering convention so that a Fault number will relate to only one specific Fault throughout the end to end Fault resolution process. The numbering convention consists of x.y. Where x indicates the phase number when the Fault was identified, and y is a number allocated to identify the Fault starting at one.

Phase Name	Phase Number (ie x.y)
Individual Location Test	1.y
Network Interworking Test	2.y
First Live Traffic Testing	3.y
Operational Field Trial	4.y

The party in which the Fault occurs is responsible for resolving the Fault. If the Fault occurs in the Interconnect Link then Batelco is responsible for resolving the Fault and may call for the reasonable assistance of the Licensed Operator in doing so. Once the Fault is resolved that party updates the Fault report with details of the solution. If the Fault is solved before the end of the related test phase, the test manager organises a retest, otherwise the overall test manager should arrange a retest. When the retest is successful the Fault report can be closed. If the retest is not successful, the Fault is sent back to the operations and development team. Again re-testing is necessary until the Fault is resolved.

Where Fault have created extreme delays due to repeated fault location, resolution and re-testing the overall test manager will decide whether to progress with the Fault resolution. This will avoid a loop in the Fault handling procedure.

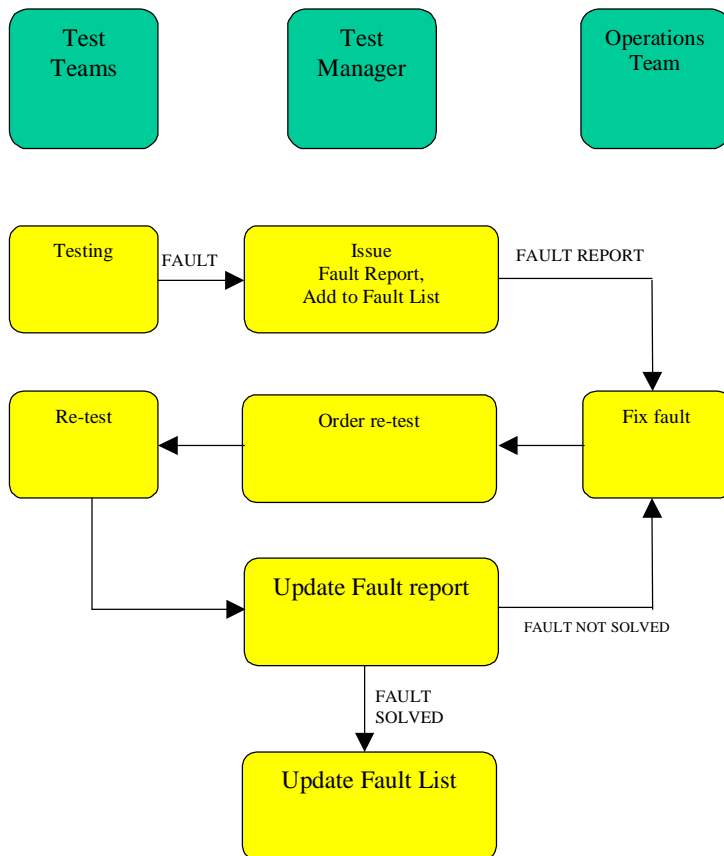

Fig. 6 – Fault Handling Procedure.

8. FAULT CLASSIFICATION

There are five categories to which a Fault can be allocated. A Fault must always be allocated to one of these categories and for each Fault it should be determined which party will take responsibility for resolving it. Corrections of the Fault should be made within the time agreed for each fault category.

Fault Category	Repair Time
----------------	-------------

Fatal	As soon as practicable
Inadmissible	3 Working Days
Major	4 weeks
Minor	before OFT
Imperfections	before general availability

Fatal Faults

A Fault is classified 'fatal' if this Fault causes a situation in which it is not possible or useful to continue testing. Fatal Faults have a significant impact on the test schedule, as all test activities will be stopped until the fault is rectified. Fatal Faults therefore need to be fixed as soon as is practicable.

Inadmissible Faults

Inadmissible Faults are not allowed in the operational phase but can be allowed in a test phase. Although a test phase can be continued if such a fault occurs, the solution for the Fault has to be available within 3 Working Days unless otherwise agreed.

Major Faults

Major Faults affect the quality of the service in operational status. After a Major Fault has been detected, the solution for the problem has to be available within four weeks unless otherwise agreed.

Minor Faults

Minor Faults also affect the quality of a service in an operational situation. However these Faults are not perceived by an end-user and are less urgent to resolve. Both parties need to determine the period of time in which the solution for these faults need to be made available/ deployed and must be completed by at least the start of the Operational Field Trial.

Imperfections

Imperfections are all Faults that do not affect the quality of service. The Fault must be solved before general availability. Depending on the situation, the solution may be covered in future upgrades.

Where there are issues concerning Fault classification and/or the cause of the Fault, the overall test managers of the parties must be consulted.

Faults have to be documented in the corresponding test reports and handled as described in the previous section.

9. ADDITIONAL ROLES AND RESPONSIBILITIES FOR TESTING

The acceptance of the Interconnect Link is the responsibility of both parties who must verify the quality of the testing process and the test results. The following paragraphs describe the roles and responsibilities that need to be filled in order to keep the test process clear and manageable. The test plan will contain contact details of the individuals in each test role.

Overall Test Manager

At each stage of testing there needs to be regular contact between the parties to track the progress of testing and resolve any issues that could arise. Each party will appoint a person who is in charge of testing and known as the overall test manager. The overall test managers should overview all test activities, planning and constantly monitor interconnect testing progress.

The overall test manager has the following responsibilities:

- completion of the test plan
- tracks progress of each test phase
- checks entry and exit criteria for each phase
- overall ownership of the Fault list for the party
- confirms completion of all test phases
- delivery of the Final Test Report
- delivers the Interconnection to the O and M phase

Test Manager

For each phase a test manager will be assigned with the following responsibilities:

- detailed planning of the test phase (documented in the test guidelines);
- execution of the tests for the corresponding test phase;
- reports testing progress to the overall test manager;
- issues Fault reports;
- maintains the Fault report list (with the overall test manager);
- completes the test report.

10. TESTING DOCUMENTATION

The testing documentation is as follows

	Document	Responsible persons
Overall	Project Plan	Overall Test Manager
	Fault List	Overall Test Manager
	Final Test Report	Overall Test Manager
Individual Location Test	ILT Test Plan	ILT Test Manager
	ILT Test Guidelines	ILT Test Manager(s)/ ILT Testers
	Fault Reports	ILT Test Manager(s)
	ILT Test Report	ILT Test Manager(s)
Network Interworking Test	NIT Test Plan	NIT Test Manager(s)
	NIT Test Guidelines	NIT Test Manager(s)/ NIT Testers
	Fault Reports	NIT Test Manager(s)
	NIT Test Report	NIT Test Manager(s)
First Live Traffic	FLT Test Plan	FLT Test Manager(s)
Testing	FLT Test Guidelines	FLT Test Manager(s)/ FLT Testers
	Fault Reports	FLT Test Manager(s)
	FLT Test Report	FLT Test Manager(s)
Operational field trial	OFT Test Plan	OFT Test Manager(s)

	OFT Test Guidelines	OFT Test Manger / OFT Testers
	Fault Reports	OFT Test Manager
	OFT Test Report	OFT Test Manager(s)

Annex 1. Summary of Tests

<p>SECTION I – PHYSICAL INSPECTION</p> <p>Ensure Footway Box termination points meet agreed standard.</p> <p>Ensure networks of both parties are prepared to agreed standard.</p> <p>Ensure both parties have interfaces that conform to agreed standards</p> <p>Test electrical wiring and grounding</p>	<p>SECTION IV – TEST CALLS</p> <p>Origination</p> <p>Routing</p> <p>Destination</p> <p>Transmission Quality</p> <p>Billing Verification/ Validation</p> <p>Billing Record Processing</p>
<p>SECTION II – LINK TESTS</p> <p>Link Code Signalling Compatibility</p> <p>Framing Compatibility</p> <p>Bit Error Rate Test (BERT): 0 over 24 hrs.</p> <p>Frame Loss: 0 over 24 hrs.</p>	<p>SECTION V – SYSTEM FAILURE and ALARM TESTS</p> <p>Verify all relevant alarm points are wired.</p> <p>Generate system alarm and validate expected notification.</p> <p>Test system failure and recovery alarms.</p> <p>Conduct system back-up and recovery procedures.</p> <p>Perform system security tests.</p>

SECTION III – SS7 SIGNALLING TESTS	SECTION VI – OPERATIONAL FIELD TRIAL
Link State Control	Operate system for agreed period.
Transmission and Reception Control	Verify system performance under load conditions.
Signalling Link Management	Monitor service quality during high traffic.
Changeover	Modify and re-test as required.
Changeback	
Forced Rerouting	
Controlled Rerouting	
Signalling Route Management	
Circuit Supervision	
Normal Telephone Call Set-up Ordinary Telephone Calls	

Annex 2. Fault Report Template for Testing

Fault Report between Batelco and Licensed Operator

Part I (to be completed by one of the test-teams)

Test Case Number:
Description of test case:
Expected result:
Observed result:
Comments (concerning the configuration, related problems, consequences, hints)
Name: _____ Date: _____ Signature: _____

Part II (to be completed by test managers)

Required action(s)	Who	Deadline	Fault classification

		(Note 1)
Test Manager	Date:	Signature:
Licensed Operator		
Test Manager	Date:	Signature:
Batelco		

Note 1:-

* = imperfection, ** = minor, *** = major, **** = inadmissible, ***** = fatal

Part III (to be completed by the test team)

Action taken to resolve fault:	
Remaining open issues:	Re-test necessary (Y/N)
Name:	Date: Signature:

Part IV (to be completed by the test team)

Result of the re-test:		
Comment:		
Name:	Date:	Signature:

Annex 3. Fault List

Problem List between Batelco and Licensed Operator

--	--	--	--	--	--	--	--

Reference Number	Switch name	Reported date/time	Cleared date/time	Outage duration	Subject	Description	Reported by	Cleared by

APPENDIX 31 – CONTACT REGISTER

BATELCO

Name	Position	Interconnection Responsibility	Phone	Fax	email

LICENSED OPERATOR

Name	Position	Interconnection Responsibility	Phone	Fax	email

APPENDIX 32 – NMC RULES

TABLE OF CONTENTS

1. INTRODUCTION	1
2. PLANNING	2
Annex 2 - End to End Interconnect Activity List	5
3. TECHNICAL SPECIFICATION	6
4. FORECASTS AND CAPACITY PROFILES	9
Annex 4A – Forecast Procedure	11
Annex 4B – Capacity Profile Procedure	12
5. INTERCONNECTION	13
Annex 5A - Key Activities – InSpan Link Service	20
Annex 5B - Key Activities – CSI Link Service	23
6. CESSATION OF CAPACITY	24
Annex 6 - Cessation of Interconnect Capacity	25
7. LIAISON	26
8. DICTIONARY	27
APPENDIX 1 - TECHNICAL SPECIFICATIONS	33
APPENDIX 2 – SPECIFICATION OF THE GENERIC ELECTRICAL AND PHYSICAL INTERFACE	39
APPENDIX 3 – SPECIFICATION OF THE GENERIC TRANSMISSION INTERFACE	44
APPENDIX 4 – SPECIFICATION OF THE GENERIC SIGNALLING SYSTEM	50
APPENDIX 5 – GSM SHORT MESSAGE SERVICE	53
APPENDIX 6 – FOOTWAY BOX ENGINEERING DRAWING	54
APPENDIX 7 – LIST OF SWITCH BUILDS AND PLATFORMS	55
APPENDIX 8 – TRANSMISSION SYSTEMS FOR INTERCONNECT LINKS	56
APPENDIX 9 – TRIBUTARY ASSIGNMENT/ALLOCATION FORMS	57
APPENDIX 10 – OPTICAL FIBRE CABLE PERFORMANCE SPECIFICATION	59
APPENDIX 11 – OPTICAL FIBRE CABLE SPECIFICATION	74
APPENDIX 12 – OPTICAL FIBRE ACCEPTANCE PROCEDURES	94
Annex 1 Optical Fibre Cable Test Record OTDR	96
Annex 2 Optical Fibre Cable Test Record POWER	98

Annex 3 Optical Fibre Cable Test Records METALLIC	99
APPENDIX 13 – TESTING OF OPTICAL LINE SYSTEMS FOR IN-SPAN INTERCONNECT	100
Annex 1 – SDH STM-1 Test Sheet	102
Annex 2 Optical Line System Test Confirmation Note	107
APPENDIX 14 – JOINT PROCEDURES FOR END TO END MULTIPLEX TRIBUTARY TESTING	108
APPENDIX 15 – SAFE WORKING PROCEDURES FOR OPTICAL FIBRE CABLES	113
APPENDIX 16 – SWITCH INFORMATION	114
APPENDIX 17 – INTERCONNECT CHANGE ADVICE FORMS	117
APPENDIX 17 - CHANGE ADVICE FORM NOTES	121
APPENDIX 18 – AUTHORISATION CERTIFICATE FOR FIRST LIVE TRAFFIC TESTING	124
APPENDIX 19 – INTERCONNECT TRAFFIC REQUIREMENTS: SUMMARY	126
APPENDIX 20 – 12 MONTH 2MBIT/S SWITCH PORT CAPACITY - ORDERING PROFILE	129
APPENDIX 21 – INTERCONNECT ORDER ACKNOWLEDGMENT	132
APPENDIX 22 – INTERCONNECT ORDER COMPLETION	134
APPENDIX 23 – ROUTE ADVICE FORMS	136
APPENDIX 24 – RFT CERTIFICATE	144
APPENDIX 25 – SWITCH TO SWITCH INTERCONNECTION AUTHORISATION CERTIFICATE	145
APPENDIX 26 – CAPACITY ORDER FORM	147
APPENDIX 27 – TESTING ESCALATION PROCESS	152
APPENDIX 28 – ROUTING PLANS	153
APPENDIX 29 – NETWORK DESCRIPTION	157
APPENDIX 30 – TESTING PROCEDURES	158
Annex 1. Summary of Tests	181
Annex 2. Fault Report Template for Testing	183
Annex 3. Fault List	186
APPENDIX 31 – CONTACT REGISTER	188
APPENDIX 32 – NMC RULES	191